

Complementi. Accessories.
Einrichtungsgegenstände. Accessoires.



BONALDO

Complementi. Accessories.
Einrichtungsgegenstände. Accessoires.

BONALDO

Bonaldo: Ottant'anni di storia

Bonaldo: Eighty years of history
Bonaldo: Achtzig Jahre Geschichte
Bonaldo: 80 ans d'histoire

En

This story began in 1936, when Giovanni Vittorio Bonaldo started up a craft-based metal working business. During the 1950s industrial production began on bedsteads, and it was extended during the '60s to iron beds. An extraordinary intuition led to the production of a folding bedstead, which went on to become a market standard, and which is still extraordinary today, considering its future implications.

The company subsequently specialised in the processing of tubular metal and invested in new machinery and technology, choices which allowed it to extend its range of products and to implement machining processes at the very cutting edge.

Today, Bonaldo designs, produces and distributes design-oriented tables, chairs, sofas, beds and interior furnishings for the Italian and the international market.

De

Diese Geschichte beginnt im Jahr 1936, als Giovanni Vittorio Bonaldo einen Handwerksbetrieb für die Metallverarbeitung eröffnet. In den Fünfzigerjahren beginnt er mit der industriellen Produktion von Lattenrosten, ab den Sechzigerjahren werden auch Metallbetten produziert. Herausragend wegen der Folgen für die Zukunft bleibt noch immer die Idee, einen klappbaren Lattenrost zu entwickeln, der später auf dem Markt zum Standard wurde.

Das Unternehmen spezialisierte sich in der Folge auf die Bearbeitung von Metallrohren und investierte in neue Maschinen und Technologien, eine Entscheidung, die die Möglichkeit bot, die Produktpalette zu erweitern und immer fortschrittlichere Verfahren anzuwenden.

Heute entwirft, produziert und vertreibt Bonaldo Tische, Stühle, Sofas, Betten und designorientierte Einrichtungsgegenstände für den italienischen und den internationalen Markt.

Fr

Une histoire qui commence en 1936, lorsque Giovanni Vittorio Bonaldo démarre une entreprise artisanale spécialisée dans la transformation des métaux. À partir des années cinquante l'entreprise se lance dans la production industrielle de sommiers à lattes et, dans les années soixante, de structures de lit en fer. L'intuition – extraordinaire à en juger par ses retombées futures – de réaliser un sommier pliant devient bientôt un standard sur le marché.

L'entreprise se spécialise par la suite dans la transformation de tubes métalliques et investit pour se doter de machines et de technologies nouvelles, autant de choix qui lui permettent d'élargir sa gamme de produits et de mettre en place des processus de plus en plus évolués.

Aujourd'hui, Bonaldo conçoit, fabrique et commercialise des tables, des chaises, des canapés, des lits et des compléments design-orientés pour le marché italien et international.

Questa storia inizia nel 1936, quando Giovanni Vittorio Bonaldo apre un'attività artigianale per la lavorazione dei metalli. A partire dagli anni Cinquanta inizia una produzione industriale di reti da letto, affiancata, negli anni Sessanta, a quella dei letti in ferro. Rimane straordinaria, per le sue implicazioni future, l'intuizione di realizzare una rete pieghevole, diventata poi uno standard di mercato.

L'azienda si specializza successivamente nella lavorazione di tubolari metallici e investe in nuovi macchinari e tecnologie, scelte che le consentono di ampliare la sua gamma di prodotti e di implementare processi sempre più evoluti. Oggi Bonaldo progetta, produce e distribuisce tavoli, sedie, divani, letti e complementi design-oriented, per il mercato italiano e internazionale.

Evoluzione

Evolution / Entwicklung / Évolution

It Sono la dedizione e l'impegno di tre generazioni imprenditoriali che hanno permesso a Bonaldo di diventare un importante punto di riferimento nel settore dell'arredamento e del design. È il forte radicamento territoriale a permettere al marchio di far crescere, nei siti di Borgoricco e Villanova, vicino Padova, una squadra di maestranze che, in molti casi, si tramanda la capacità artigianale di padre in figlio.

De Die Hingabe und der Einsatz von drei Unternehmergenerationen machten aus Bonaldo einen wichtigen Bezugspunkt in der Möbel- und Designbranche. Durch die starke lokale Verwurzelung konnte das Unternehmen an den Standorten Borgoricco und Villanova, in der Nähe von Padua, eine Belegschaft aufbauen, die oft das handwerkliche Können vom Vater an den Sohn weitergibt.

En It is the dedication and commitment that have been passed down three generations of entrepreneurs that have enabled Bonaldo to become a major benchmark in the furniture and design industry. Bonaldo's strong ties to the local area have enabled the brand to grow and develop, in the Borgoricco and Villanova sites near Padua, a team of experts who, in many cases, have been craftsmen from one generation to the next.

Fr C'est la passion et l'engagement de trois générations d'entrepreneurs qui ont permis à Bonaldo de devenir une référence incontournable dans le secteur de l'ameublement et du design. Et c'est grâce à son enracinement territorial que la marque a pu développer, sur les sites de Borgoricco et Villanova près de Padoue, une équipe d'ouvriers qui transmettent souvent leurs capacités artisanales de père en fils.

Albino Bonaldo,
President

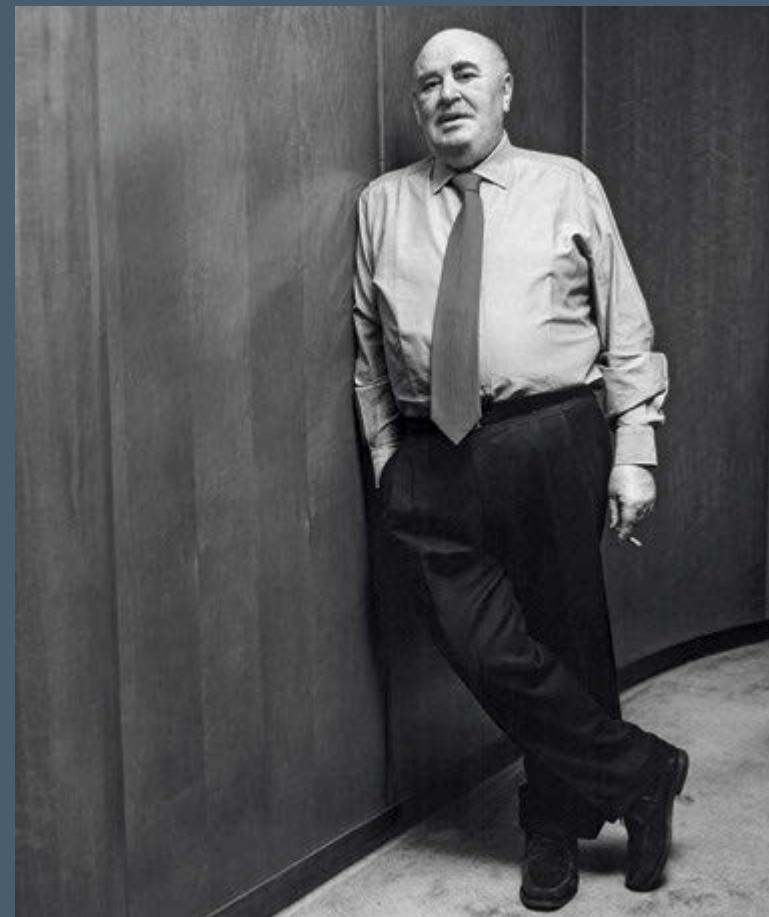

Ricerca e creazione

Research and creativity / Forschung und Kreativität / Recherche et création

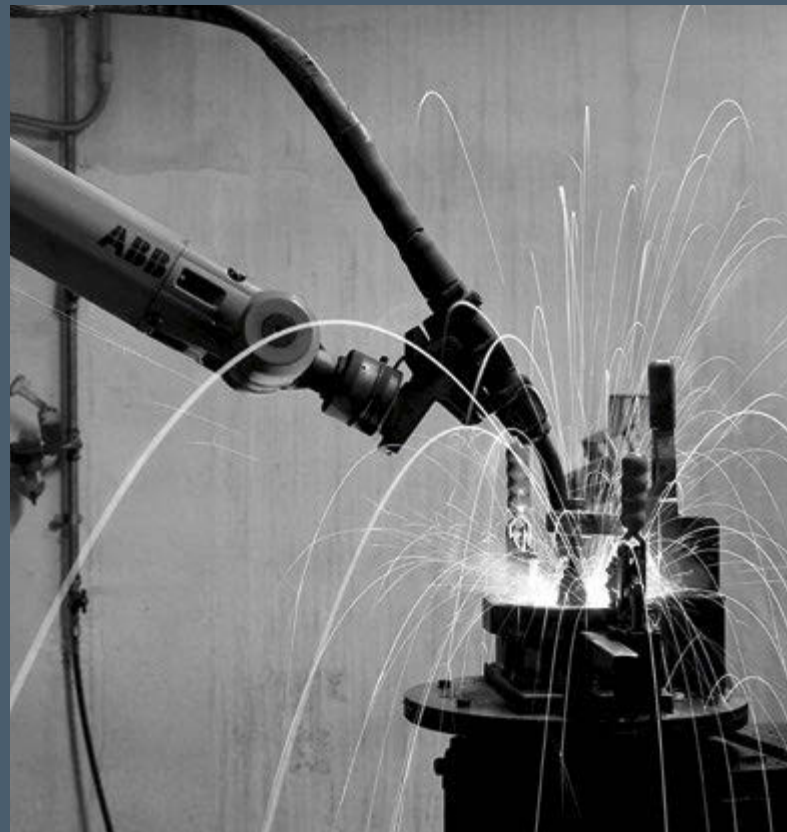

Tecnologia, manualità e organizzazione.
Conoscenze tecniche e abilità manuali rappresentano i punti di riferimento di una struttura industriale moderna e competitiva che possiede una cultura dell'oggetto fatto secondo i canoni della migliore tradizione italiana.

Technology, manual skill and organization.
Technical knowledge and manual dexterity represent the reference points for a modern and competitive industrial organization that possesses a culture of products created in line with the best principles of Italian tradition.

Technologie, Handwerk und perfekte Organisation.
Technisches Know-how und handwerkliches Geschick bilden die Eckpfeiler eines modernen, wettbewerbsfähigen Industriebetriebs, der auf Designkultur nach bester italienischer Tradition setzt.

Technologie, habileté et organisation.
Les connaissances techniques et le savoir-faire manuel représentent les points forts d'une structure industrielle moderne et compétitive qui possède une culture de l'objet réalisé selon les critères de la plus belle tradition italienne.

IT È la capacità di rimanere ancorati al Made in Italy, laddove questo si concretizza in una coerente attenzione alla scelta dei materiali, alla lavorazione in loco di ogni singolo componente, ad un processo di controllo attento e rigoroso.

È, infine, il costante investimento in Ricerca e Sviluppo che permette a Bonaldo di realizzare prodotti capaci di soddisfare le esigenze e i gusti di un pubblico dinamico ed internazionale.

En Bonaldo's ability to remain true to the spirit of excellence Made in Italy can be seen in the painstaking care with which materials are selected, the on-site processing of every single component and a strict and careful control process.

Last but not least, ongoing investments in Research and Development have enabled the Bonaldo brand to manufacture products designed to accommodate the needs and tastes of a dynamic, international target.

De Das Unternehmen ist auch im „Made in Italy“ verankert, das bedeutet großes Augenmerk für die Auswahl der Materialien, die Bearbeitung jedes einzelnen Bestandteils vor Ort und strenge und gewissenhafte Qualitätskontrollen.

Durch die ständigen Investitionen in Forschung und Entwicklung ist Bonaldo schließlich in der Lage, Produkte zu erzeugen, die den Ansprüchen und dem Geschmack eines dynamischen und internationalen Publikums entsprechen.

Fr C'est la capacité de rester fidèle au Made in Italy, fidélité qui se traduit par une attention cohérente au choix des matériaux, par la transformation sur site de chaque composant, et par un processus de contrôle attentif et rigoureux.

Ce sont enfin des investissements constants dans la Recherche et Développement qui permettent à Bonaldo de réaliser des produits capables de satisfaire les exigences et les goûts d'un public dynamique et international.

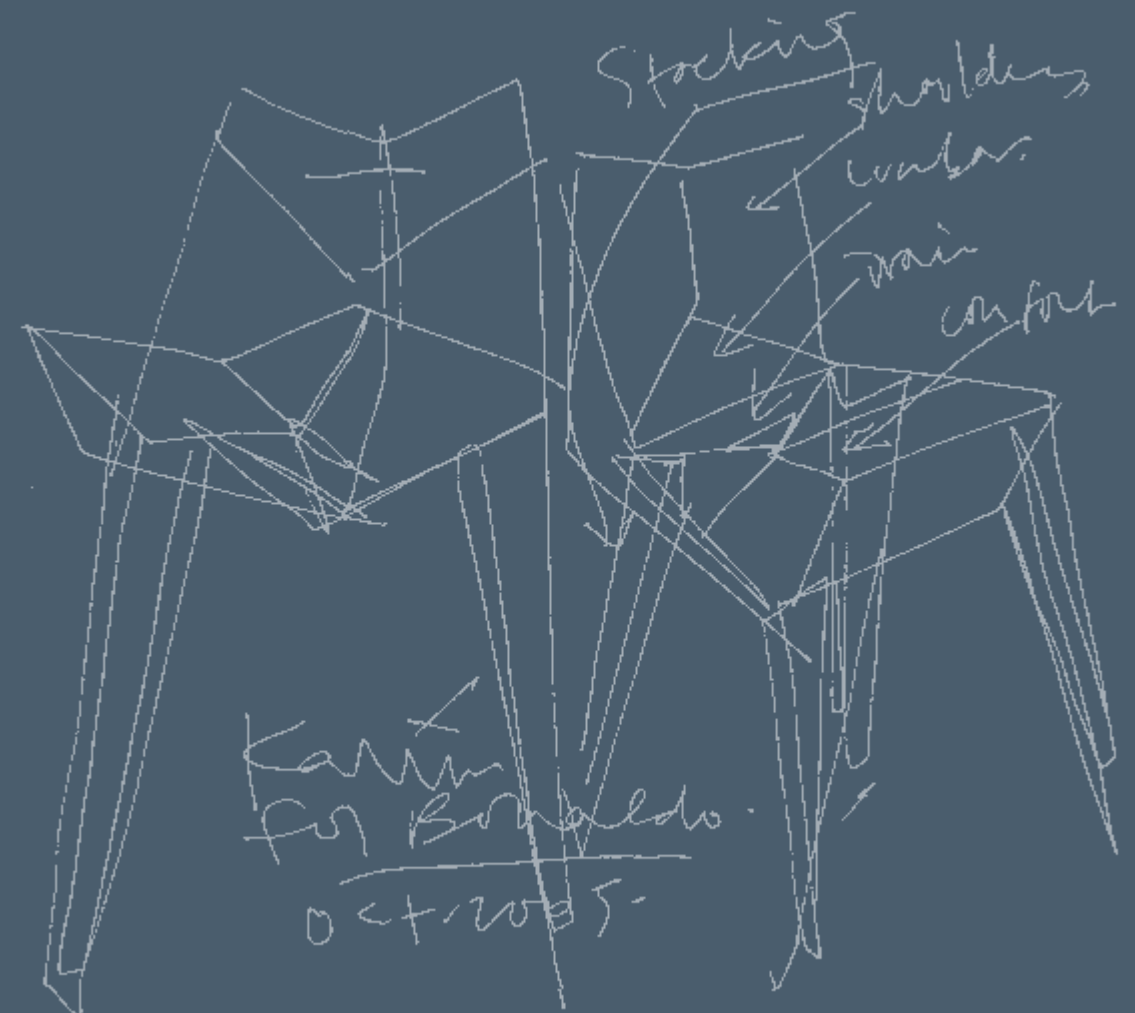

L'azienda

The company / Das Unternehmen / L'entreprise

1. UFFICI E UNITÀ PRODUTTIVA 1
Villanova di Camposampiero (PD)
16.000 mq
Ospita la produzione di tavoli e sedie

OFFICES AND PRODUCTION UNIT 1
Villanova di Camposampiero (PD)
16,000 m²
Houses the production of tables and chairs

BÜROS UND PRODUKTIONSEINHEIT 1
Villanova di Camposampiero (PD)
16.000 m²
Hier erfolgt die Produktion von Tischen und Stühlen

BUREAUX ET UNITÉ DE PRODUCTION N°1
Villanova di Camposampiero (Padoue)
16 000 m²
Production de tables et chaises

It Sono tre i luoghi della produzione nei quali il “made in Italy” Bonaldo assume corpo e sostanza. Tre strutture che assolvono il compito di dare forma tangibile ai contenuti della marca.

De In drei Produktionsstätten nehmen die Produkte “Made in Italy” von Bonaldo Körper und Gestalt an. Es gibt drei Standorte, die dem Inhalt der Marke eine greifbare Form geben.

En There are three production sites where excellence “made in Italy” by Bonaldo come to life. Three facilities which have the task of giving a tangible shape to the brand's concepts.

Fr Le Made in Italy Bonaldo prend corps dans trois sites de production, trois structures qui accomplissent la tâche de donner une forme tangible aux contenus de la marque.

2. UFFICI E UNITÀ PRODUTTIVA 2
Borgorico (PD)
7.000 mq
Qui vengono realizzati letti e divani.

BÜROS UND PRODUKTIONSEINHEIT 2
Borgorico (PD) 7.000 m²
Hier werden Sofas und Betten hergestellt.

OFFICES AND PRODUCTION UNIT 2
Borgorico (PD)
7,000 m²
This is where beds and sofas are made.

BUREAUX ET UNITÉ DE PRODUCTION N°2
Borgorico (Padoue)
7000 m²
Production de canapés et lits

3. SHOWROOM
Borgorico (PD)
6.000 mq
Immerso nella campagna veneta, è il luogo dell'incontro, della relazione, dello scambio.

SHOWROOM
Borgorico (PD)
6.000 m²
Ein Ort der Begegnung, der Kontakte und des Austauschs, mitten im venezianischen Hinterland.

SHOWROOM
Borgorico (PD)
6,000 m²
Set in the Veneto countryside, it is the place for meeting, relating, exchanging.

SHOWROOM
Borgorico (Padoue)
6000 m²
Plongé dans la campagne vénète, il est le lieu de la rencontre, de la relation et de l'échange.



Showroom



Il Good Design Award è un riconoscimento istituito dal Chicago Athenaeum, prestigioso centro culturale statunitense dedicato al design in tutte le sue accezioni e declinazioni.

The Good Design Award is a prize offered by the Chicago Athenaeum, the famous US cultural centre dedicated to design in all its meanings and applications.

Der Good Design Award ist eine Auszeichnung des Chicago Athenaeum. Das renommierte amerikanische Kulturzentrum befasst sich mit Design in allen Varianten und Ausdrucksformen.

Le Good Design Award est un prix décerné par le Chicago Athenaeum, un centre culturel étatsunien de prestige consacré au design sous toutes ses formes et ses déclinaisons.

En

Following a major restyling process that involved a surface area of approximately 6,000 m², one of the former production units was turned into the new company showroom. The showroom is now a charming and disarming setting that is the perfect place to admire Bonaldo collections, from the latest new products to icons from the past.

The space, which is also used for presentations and workshops, tells the story of the brand from the onset.

The entrance to the showroom stands out for a pathway created using colour-changing stones sourced in China, the surface of which modifies at low temperatures, creating grain patterns that recall flower motifs.

Inside the showroom, two winter gardens add further charm to the setting, with lights and colours designed to beguile visitors. In 2011, the showroom project was awarded the prestigious “Good Design Award” by the Chicago Athenaeum.

De

Die frühere Produktionsstätte mit einer Fläche von circa 6.000 m² wurde in umfangreichen Renovierungsarbeiten in den Showroom des Unternehmens umgebaut.

Der Showroom ist heute ein eindrucksvoller und spannender Ort, an dem man die Bonaldo-Kollektionen bewundern kann, von den neuen Produkten bis zu den Bonaldo-Ikonen.

Der Raum, der auch für Präsentationen und Workshops genutzt wird, erzählt die Geschichte der Marke seit den Anfängen. Der Eingang zum Showroom ist mit changierenden Steinen aus China gepflastert. Bei niedrigen Temperaturen verändert sich die Oberfläche des Steins, es entsteht eine Maserung, die an Blumenmuster erinnert.

Im Inneren des Ausstellungsraumes verleihen zwei Wintergärten dem Raum noch mehr Atmosphäre, mit überraschenden Licht- und Farbeffekten. Der Entwurf wurde 2011 mit dem renommierten Preis „Good Design Award“ des Chicago Athenaeum ausgezeichnet.

Fr

Suite à une importante opération de requalification, une surface d'environ 6 000 m² d'une ancienne unité de production a pu devenir le showroom de l'entreprise.

Le showroom est maintenant un lieu magnifique où l'on peut admirer les collections Bonaldo, des dernières nouveautés aux produits phare.

L'espace, qui est également utilisé pour des présentations et des workshops, raconte l'histoire de la marque depuis ses origines.

L'entrée du showroom est caractérisée par un parcours marqué de pierres aux couleurs chatoyantes provenant de Chine et dont la surface se modifie à basse température pour créer un veinage aux motifs floraux.

À l'intérieur de l'espace d'exposition, deux jardins d'hiver apportent un charme supplémentaire avec un éclairage et des couleurs qui surprennent le visiteur. Le projet a reçu en 2011 le prestigieux prix « Good Design Award » du Chicago Athenaeum.

Dopo un importante intervento di riqualificazione, che ha coinvolto una superficie di circa 6.000 mq, una delle vecchie unità produttive è stata trasformata nello showroom aziendale. Lo showroom è ora un luogo suggestivo ed emozionante, in cui è possibile ammirare le collezioni Bonaldo, dai nuovi prodotti alle icone. Lo spazio, che viene utilizzato anche per presentazioni e workshop, racconta la storia del marchio a partire dalle origini. L'ingresso dello showroom è caratterizzato da un percorso realizzato con pietre cangianti provenienti dalla Cina, la cui superficie si modifica con le basse temperature, creando venature che ricordano motivi floreali. All'interno dello spazio espositivo due giardini d'inverno offrono ulteriore emozione allo spazio, con luci e colori che sorprendono il visitatore. Il progetto ha ricevuto nel 2011 il prestigioso riconoscimento “Good Design Award” del Chicago Athenaeum.



Architetti e Designer

Sono oltre 25 i designer e architetti italiani ed internazionali che negli anni hanno contribuito a interpretare lo stile Bonaldo, tra questi Karim Rashid, Bartoli Design, Mauro Lipparini, Toshiyuki Kita, Alain Gilles...e che hanno dato all'azienda un gusto sempre più internazionale. Sono la sensibilità e la lungimiranza a permettere all'azienda non solo di instaurare un proficuo rapporto con designer e architetti di fama mondiale, ma anche di vincere i più prestigiosi premi internazionali del settore del design.

En

Architects and Designers

Over 25 different Italian and international designers and architects have contributed over the years to interpret the Bonaldo style, including Karim Rashid, Bartoli Design, Mauro Lipparini, Toshiyuki Kita, Alain Gilles...giving the brand an increasingly international outlook. Sensitivity and forward-thinking have enabled Bonaldo not only to establish a successful partnership with world-famous designers and architects, but also to win some of the most prestigious international design awards.

De

Architekten und Designer

Über 25 italienische und internationale Designer und Architekten haben in den vergangenen Jahren den Stil von Bonaldo mitinterpretiert, unter ihnen Karim Rashid, Bartoli Design, Mauro Lipparini, Toshiyuki Kita, Alain Gilles...und sie haben dem Unternehmen eine immer internationalere Linie gegeben. Mit Feingefühl und Weitblick hat das Unternehmen nicht nur eine fruchtbare Beziehung mit Designern und Architekten von Weltruhm aufgebaut, sondern auch die renommiertesten Preise im Designbereich gewonnen.

Fr

Architectes et designers

Karim Rashid, Bartoli Design, Mauro Lipparini, Toshiyuki Kita, Alain Gilles, ce ne sont que quelques noms des plus de 25 designers et architectes italiens et internationaux qui ont contribué au fil des années à interpréter le style Bonaldo, en donnant à l'entreprise une touche toujours plus internationale; La sensibilité et la clairvoyance de l'entreprise ont permis non seulement d'instaurer un rapport fructueux avec des designers et architectes de réputation mondiale, mais aussi de remporter les prix internationaux les plus prestigieux dans le secteur du design.

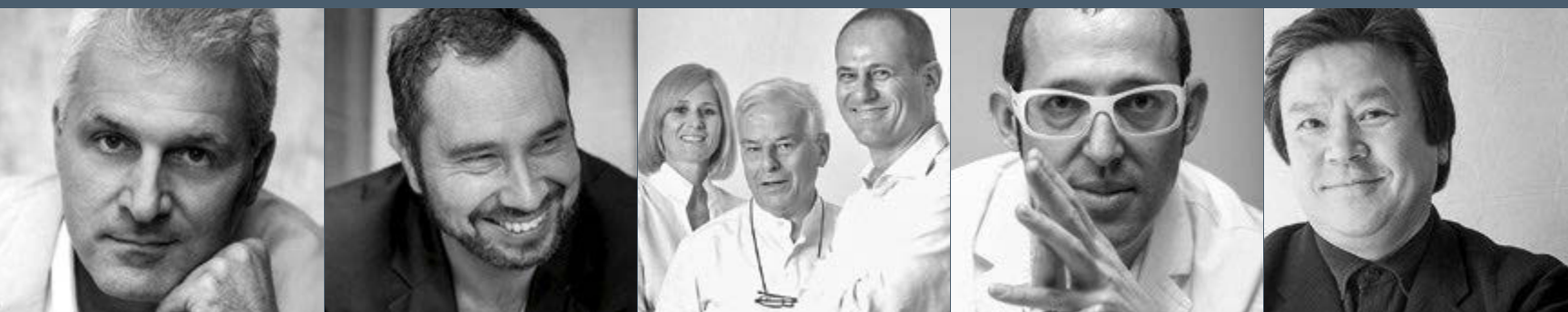

Premi

I premi ottenuti da Bonaldo in questi anni hanno sicuramente rafforzato la notorietà del brand e dei suoi prodotti, in Italia e soprattutto all'estero, dove viene rivolta molta attenzione a quelle peculiarità del Made in Italy (materiali pregiati, qualità dei progetti e dei prodotti) che sono parte integrante della filosofia aziendale. In questo contesto, negli ultimi anni è accresciuta la presenza del marchio all'interno dei punti vendita in tutto il mondo, non solo con singoli prodotti, ma con spazi dedicati.

En

Awards

The awards bestowed upon Bonaldo over the years have definitely enhanced brand and product awareness, in Italy and especially abroad, where particular focus is placed on excellence Made in Italy (fine materials, quality designs and products) which form an integral part of the corporate philosophy. To this end, the brand's presence has grown in outlets across the globe, and not just with individual products, but with dedicated spaces too.

De

Preise

Die Preise, die Bonaldo in diesen Jahren erhalten hat, haben sicher die Bekanntheit der Marke und der Produkte in Italien und vor allem im Ausland, wo die Qualitäten des Labels „Made in Italy“ (hochwertige Materialien, hohe Qualität der Entwürfe und Produkte) - ein fester Bestandteil der Firmenphilosophie - große Beachtung finden, gefördert. Dadurch ist in den vergangenen Jahren die Präsenz der Marke in den Verkaufsstellen weltweit gestiegen, und nicht nur mit Einzelprodukten sondern auch mit Verkaufsflächen, die der Marke gewidmet sind.

Fr

Prix

Les prix obtenus au fil des ans par Bonaldo ont sans aucun doute renforcé la notoriété de la marque et de ses produits, non seulement en Italie, mais aussi à l'étranger, où l'on accorde une attention particulière au Made in Italy et à ses spécificités (matériaux nobles, projets et produits de qualité), qui font partie intégrante de la philosophie d'entreprise. Dans ce contexte, la présence de la marque s'est intensifiée au cours de ces dernières années dans les points de vente du monde entier, et non seulement en termes de produits proposés mais également en surface d'espaces dédiés.

BEST
DESIGN

reddot design award



Complementi. Accessories. Einrichtungsgegenstände. Accessoires.

CONSOLLE / CONSOLE / KONSOLE / CONSOLE

Amond Console P.26	AX Console P.22	Coseno P.30
-----------------------	--------------------	----------------



CREDENZE / SIDEBARDS / SIDEBARDS / BUFFETS

Doppler Sideboard P.52	Frame Sideboard P.40	Note Sideboard P.48	Spring P.62	Summer P.64	Sunrise Sunrise Light P.58	Tratto P.34
---------------------------	-------------------------	------------------------	----------------	----------------	----------------------------------	----------------



TAVOLINI / COFFEE TABLES / COUCHTISCHE / TABLES BASSES

Arvo P.118	Bend P.80	Collage P.100	Cosmos Cosmos Light P.92	Doppler P.76	Duffy P.112	Fard P.78	Folio P.98	Icosi P.108	Kadou Coffee P.102	Mille Coffee P.96	Monforte P.68
---------------	--------------	------------------	--------------------------------	-----------------	----------------	--------------	---------------	----------------	-----------------------	----------------------	------------------



Muffin Muffin Light P.114	Orion P.90	Pebble P.120	Planet Planet Light Big Planet Big Planet Light P.86	Ribbon P.94	Tectonic P.106	Tie P.72	Vanity, Fortuny, Harry P.110	Voilà P.84
---------------------------------	---------------	-----------------	--	----------------	-------------------	-------------	---------------------------------------	---------------

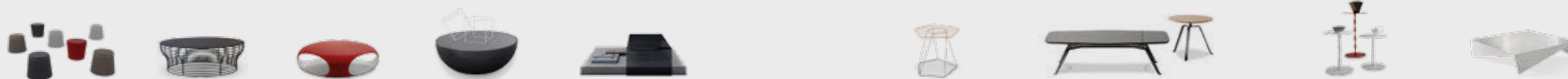







PORTARIVISTE / MAGAZINE RACK / ZEITSCHRIFTENSTÄNDER / PORTE-REVUES

Magazine Bag P.124



Complementi. Accessories. Einrichtungsgegenstände. Accessoires.



LIBRERIE / BOOKCASES / BÜCHERREGALE / ÉTAGÈRES

April, May, June P.128	Cubic P.142	Cubic Glass P.144	Fun P.140	Note P.132	Up and Down Up and Down Light P.138
					

SPECCHI / MIRRORS / SPIEGEL / MIROIRS

Amond Mirror P.172	AX Mirror P.170	Azero P.180	Eclipse P.182	Hang up P.176	New Perspective Mirror P.164	Obel P.178	Piers P.168	Spiral Mirror P.174
								



PORTA TV / TV UNITS / TV-MÖBEL / MEUBLES-TÉLÉVISION

Panorama P.190	Vision P.192
	

APPENDIABITI E LAMPADE / COAT STANDS AND LAMPS / KLEIDERSTÄNDER UND LAMPEN / PORTE-MANTEAUX ET LAMPES

Eos Eos Light P.158	Kadou Kadou Light P.146	Muffin Lamp P.160	Tree Tree Light P.152	XXLight P.162
				

POUF

Cube P.188	Hollywood P.184	Pebble Pouf P.122
		

Complementi Bonaldo: oggetti destinati ad entrare da protagonisti nelle nostre case, in piena sintonia con le scelte stilistiche di ognuno. Per la capacità di rispondere alle esigenze concrete della nostra vita quotidiana. Per le scelte di materiali di prestigio ed eleganza. Per una dimensione progettuale sempre attenta all'unicità di ogni oggetto. Perché ogni oggetto Bonaldo esprime un mondo di qualità e valore. Complementi Bonaldo, per la vostra idea di casa.



Complementi. Accessories. Einrichtungsgegenstände. Accessoires

En Bonaldo accessories are to become key features in our homes, in full harmony with each person's style choices. They can respond to the actual needs of our everyday life. The materials are prestigious and elegant. The design dimension always considers the uniqueness of every item. As every Bonaldo item expresses a world of quality and value. Bonaldo accessories are for your idea of home.

De Einrichtungsgegenstände von Bonaldo. Das sind Möbel und Accessoires, die in Ihrem Heim Akzente setzen und sich zugleich harmonisch in Ihren individuellen Stil einfügen. Die den konkreten Anforderungen des Alltags gewachsen sind. Die durch hochwertige Materialien und elegante Optik bestechen. Deren Design den Wert der Einzigartigkeit kennt. Weil Produkte von Bonaldo für Qualität und Wertigkeit stehen. Einrichtungsgegenstände von Bonaldo – Wohnen ganz nach Ihrem Geschmack.

Fr Compléments Bonaldo : des objets destinés à se faire remarquer dans nos intérieurs, en parfaite harmonie avec les différents choix stylistiques. Pour leur capacité à répondre aux exigences concrètes de notre vie quotidienne. Pour la noblesse et l'élégance des matériaux choisis. Pour une approche conceptuelle toujours attentive au caractère unique de chaque objet. Car chaque objet Bonaldo est l'expression d'un univers de qualité et de valeur. Compléments Bonaldo, pour votre idée d'intérieur.

AX Console

Geometrica, rigorosa, lineare.
Per valorizzare la semplicità della
forma, la console AX punta
all'essenziale: i due "fogli" in metallo
verniciato creano una V rovesciata di
supporto al piano.
Il piano ripropone le forme e gli
angoli del tavolo AX a cui si ispira.

En Geometric, rigorous and linear:
To enhance the simplicity of its
shape, the AX Console focuses
on the essential aspect. The two
painted metal "sheets" create an
overturned V shape to support the
top. The top reflects the shapes
and corners of the AX table which
inspired it.

De Geometrisch, streng linear:
Die Konsole AX punktet
mit schlichten Formen und
konzentriert sich formal auf
Wesentliche: Als Gestell dienen
zwei „Blätter“ aus lackiertem Metall
in Form eines umgedrehten Vs.
Die Auflageplatte greift bewusst
die Form und Kantengestaltung des
gleichnamigen Tisches auf.

Fr Géométrique, stricte, linéaire.
Pour valoriser la simplicité de la
forme, la console AX mise sur
l'essentiel : les deux « feuilles » en
métal verni forment un V renversé
et constituent la base du plateau
qui reprend les formes et les
angles de la table AX dont elle est
inspirée.

AX Console Gino Carollo
Consolle. Console. Konsolle. Console.
AX Mirror Gino Carollo
Specchio. Mirror. Spiegel. Miroir.

Ceramica Paonazzetto / brunito
Paonazzetto ceramic / burnished
Paonazzetto Ceramic / Brûniert
Céramique Paonazzetto / bruni





AX Console Gino Carollo
 Consolle. Console. Konsole. Console.
AX Mirror Gino Carollo
 Specchio. Mirror. Spiegel. Miroir.

Noce americano / brunito
 American walnut / burnished
 Amerikaner Nussbaum / Brüniert
 Noyer américain / bruni



Amond Console

La consolle Amond presenta un elegante gioco di contrasti tra lo spessore del piano in legno e la base in metallo, caratterizzata dall'assenza di volumi pieni e dall'originale silhouette che ricorda un diamante. Ed è proprio l'alternanza tra volumi vuoti e pieni a far sì che la base sembri sospesa nel vuoto, comunicando un senso di leggerezza, stesse caratteristiche del tavolo Amond.

En The Amond Console presents an elegant play of contrasts between the thickness of the wooden top and the metal base, marked by the absence of full volumes and the original silhouette that resembles a diamond. Indeed, it is this very alternation of blocks and voids that makes the base appear to be suspended in mid-air, conveying a sense of lightness, the same features as the Amond table.

De Die Konsole Amond spielt auf elegante Weise mit dem Kontrast zwischen der massiven Holzplatte und dem Untergestell aus Metall, das mit minimalem materiellem Volumen auskommt und dessen originelle Silhouette an einen Diamanten erinnert. Dieser Gegensatz zwischen Fülle und Leere verleiht dem Gestell etwas Schwebendes und vermittelt ein überraschendes Gefühl von Leichtigkeit – ebenso wie die Ausführung als Tisch.

Fr La console Amond présente un jeu de contrastes de la plus grande élégance entre le plateau en bois et la base en métal, caractérisée par l'absence de volumes pleins et par sa silhouette originale qui évoque la forme d'un diamant. Et c'est cette alternance justement entre vides et pleins qui donne l'impression que la base est suspendue dans le vide, transmettant ainsi une sensation de légèreté, tout comme dans la table Amond.

Amond Console Gino Carollo
Consolle. Console. Konsole. Consolle.

Amond Mirror Gino Carollo
Specchio. Mirror. Spiegel. Miroir.

Rovere grigio antracite / decapato
Anthracite grey oak / pickled
Eiche Anthrazitgrau / Stahlgrau
Rouvre gris anthracite / décapé





Amond Console Gino Carollo
Consolle. Console. Konsole. Console.
Amond Mirror Gino Carollo
Specchio. Mirror. Spiegel. Miroir.

Rovere naturale / acciaio spazzolato
Natural oak / polished steel
Eiche Natur / Stahl poliert
Rouvre naturel / acier brossé

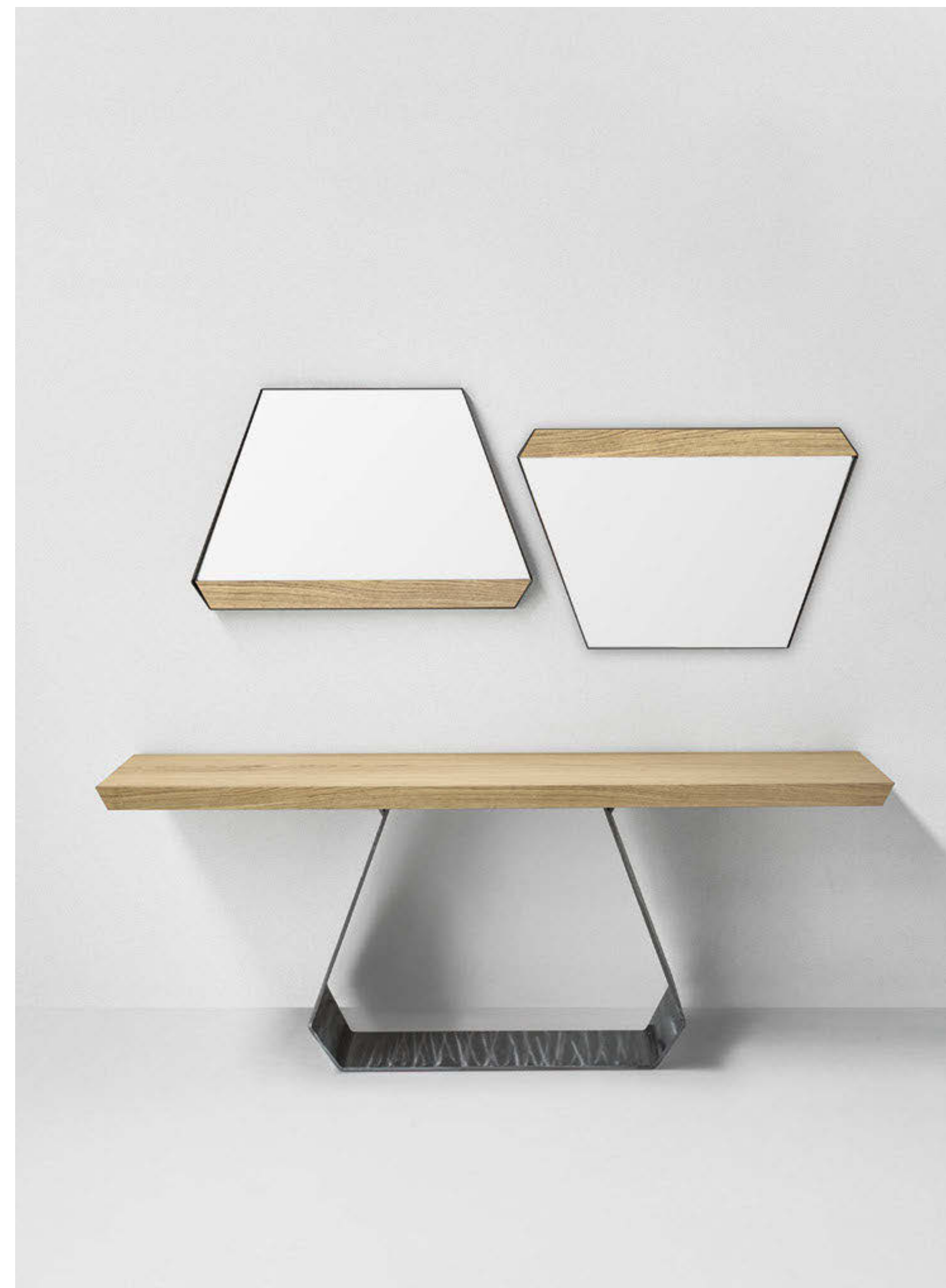

Coseno

Leggera negli elementi strutturali tubolari, forte nello spessore del piano, Coseno è una consolle multifunzione: piano d'appoggio, mobile toilette, specchio. Proprio per queste caratteristiche, risulta un oggetto ideale sia in zona ingresso, sia in zona notte.

En Light tubular structural elements with the strength of the thick table top, Coseno is a multifunctional console: a display surface, dressing table and mirror. Precisely because of these features, it is an ideal item to be placed either in the hallway or the bedroom.

Fr Une structure tubulaire légère sous un plan d'une épaisseur plus massive. Coseno est une console multifonction, surface où déposer des objets divers, coiffeuse, miroir; ce qui en fait un meuble idéal aussi bien dans une entrée que dans la zone nuit.

De Leichtfüßig präsentiert sich das Gestell aus Rundrohr; stabil die solide Auflageplatte. Die Konsole Coseno ist ein echtes Multifunktionaltalent – Ablage, Toilettentisch und Spiegel zugleich. In anderen Worten, das ideale Möbelstück sowohl für den Eingangs- als auch den Schlafbereich.



Coseno Mauro Lipparini
Consolle. Console. Konsole. Console.

Pag. 30. 31. 32. 33
Noce Canaletto / finitura rame opaco
Canaletto Walnut / mat copper finish
Nussbaum Canaletto / Kupfer matt Ausführung
Noyer Canaletto / finition cuivre opaque





Coseno Mauro Lipparini
Consolle. Console. Konsole. Console.





Tratto

La madia Tratto si presenta con geometrie essenziali ma raffinate, con un sofisticato gioco di volumi pieni e volumi vuoti e di alternanze cromatiche dovute alla varietà di finiture disponibili. Per purezza di segno, è una scelta che ben si adatta a diversi ambienti.

En The Tratto sideboard has essential but refined geometries, with a sophisticated play on blocks and voids and alternating colours due to the variety of finishes available. With its sign of purity, it is well suited to different settings.

De Das Sideboard Tratto überzeugt mit ebenso schlichten wie raffinierten geometrischen Formen, einem spannenden Wechselspiel zwischen offenen und geschlossenen Flächen und – dank einer breiten Auswahl möglicher Ausführungen – verschiedenen Farben. Sein unverfälschtes Design fügt sich perfekt in die unterschiedlichsten Umgebungen.

Fr Le buffet Tratto présente une géométrie sobre mais sophistiquée, avec un jeu de volumes plein et vides, mais aussi une intéressante alternance de couleurs due à la variété des finitions proposées. De par la pureté de son design, Tratto trouve parfaitement sa place dans les espaces les plus divers.



Rovere naturale / bordeaux
Natural oak / bordeaux
Eiche Natur / bordeaux
Rouvre naturel / bordeaux

Tratto Mauro Lipparini
Credenza. Sideboard. Sideboard. Buffet.



Tratto Mauro Lipparini
Credenza. Sideboard. Buffet.

Pag. 36-37, 38, 39
Noce Canaletto / grigio antracite
Walnut Canaletto / anthracite grey
Nussbaum Canaletto / Anthrazitgrau
Noyer Canaletto / gris anthracite



Tratto Mauro Lipparini
Credenza. Sideboard. Sideboard. Buffet.



Frame Sideboard

Una struttura (frame) in metallo, che dà il nome alla credenza, pannelli laterali e piano in legno inseriti nella struttura, lasciando uno spazio vuoto: la collezione Frame rappresenta un modo decisamente alternativo di progettare una madia. Gli angoli smussati rendono visibile la struttura metallica e conferiscono dinamicità alla madia, disponibile in tre versioni (Low, Medium, High).

En A metal frame, which gives its name to the sideboard, wooden side panels and top inserted into the frame, leaving an empty space. The Frame collection decisively represents an alternative way to design a sideboard. The rounded corners leave the metal frame visible and give a dynamic sense to the sideboard, which is available in three versions (Low, Medium and High).

De Das Gestell (Frame) aus Metall verleiht dem Sideboard seinen Namen, die Seitenwände und die Auflageplatte aus Holz gewähren diesem auch optisch Raum. Denn die Kollektion Frame umfasst Sideboards der etwas anderen Art. Die großzügig abgerundeten Kanten geben den Blick auf das Metallgestell frei und verleihen dem Sideboard unerwartete Dynamik. Erhältlich in drei Größen (Low, Medium, High).

Fr Une structure (frame) en métal qui donne son nom à ce buffet, et dans laquelle viennent s'intégrer les panneaux latéraux et le plan en bois, laissant un espace vide : la collection Frame propose une vision décidément alternative du buffet. Les angles arrondis font apparaître la structure métallique et confèrent un côté dynamique au buffet, disponible en trois versions (Low, Medium, High).

Frame Sideboard Alain Gilles
Credenza. Sideboard. Sideboard. Buffet.

Rovere naturale / bordeaux
Natural oak / bordeaux
Eiche Natur / bordeaux
Rouvre naturel / bordeaux



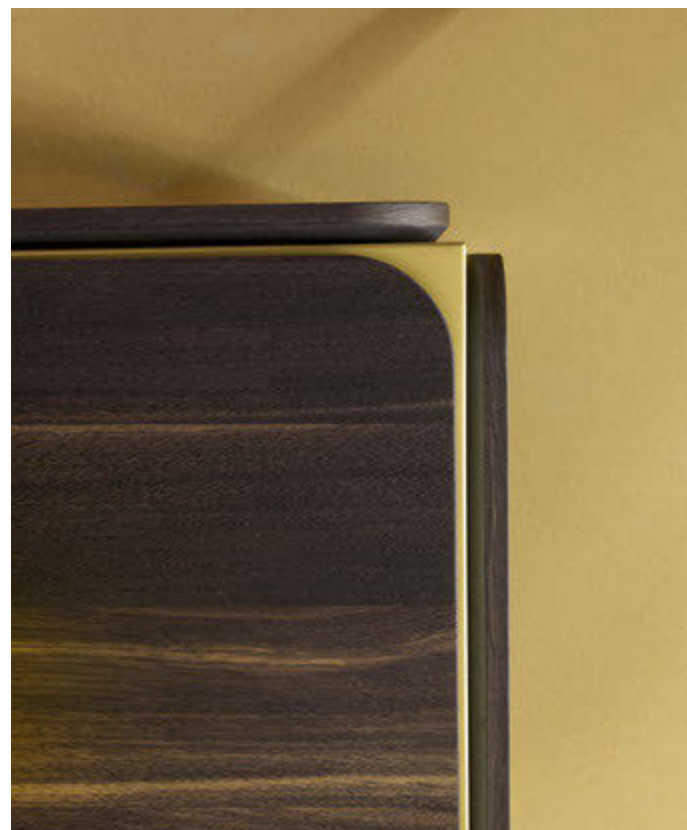
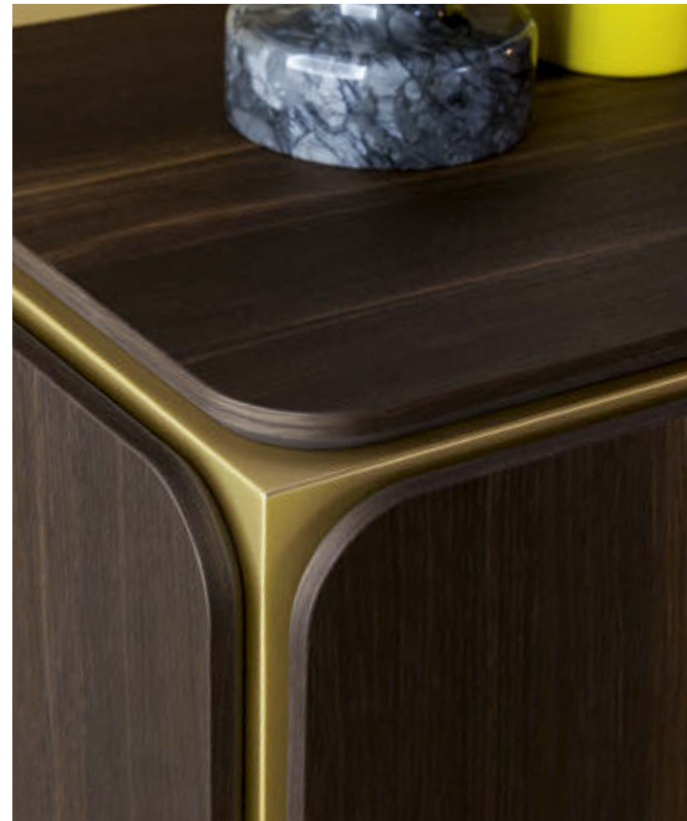

Frame Sideboard Alain Gilles
Credenza. Sideboard. Sideboard. Buffet.

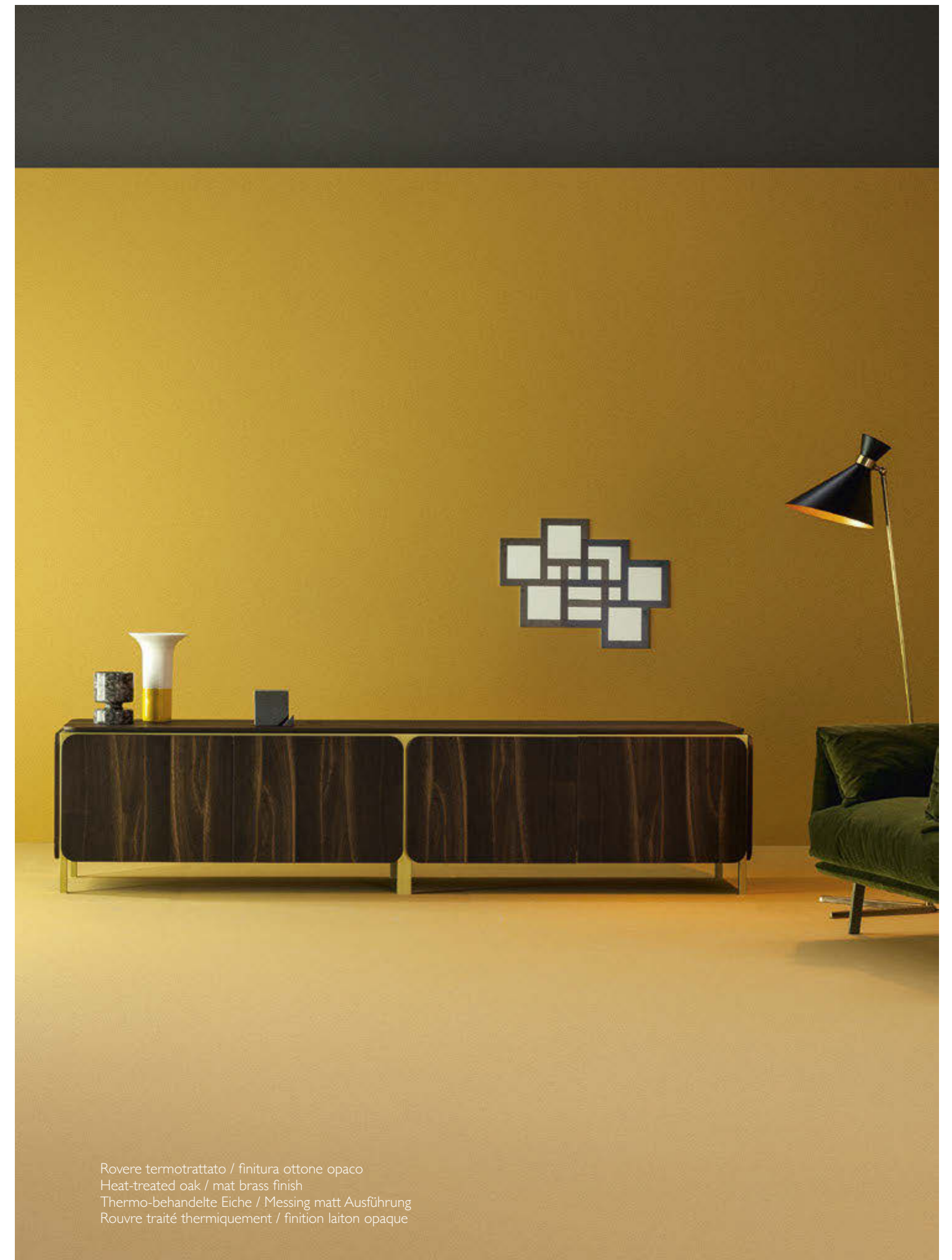

Rovere termotrattato / finitura ottone opaco
Heat-treated oak / mat brass finish
Thermo-behandelte Eiche / Messing matt Ausführung
Rouvre traité thermiquement / finition laiton opaque



Frame Sideboard Alain Gilles
Credenza. Sideboard. Sideboard. Buffet.

Rovere grigio antracite / grigio antracite
Anthracite grey oak / anthracite grey
Eiche Anthrazitgrau / Anthrazitgrau
Rouvre gris anthracite / gris anthracite

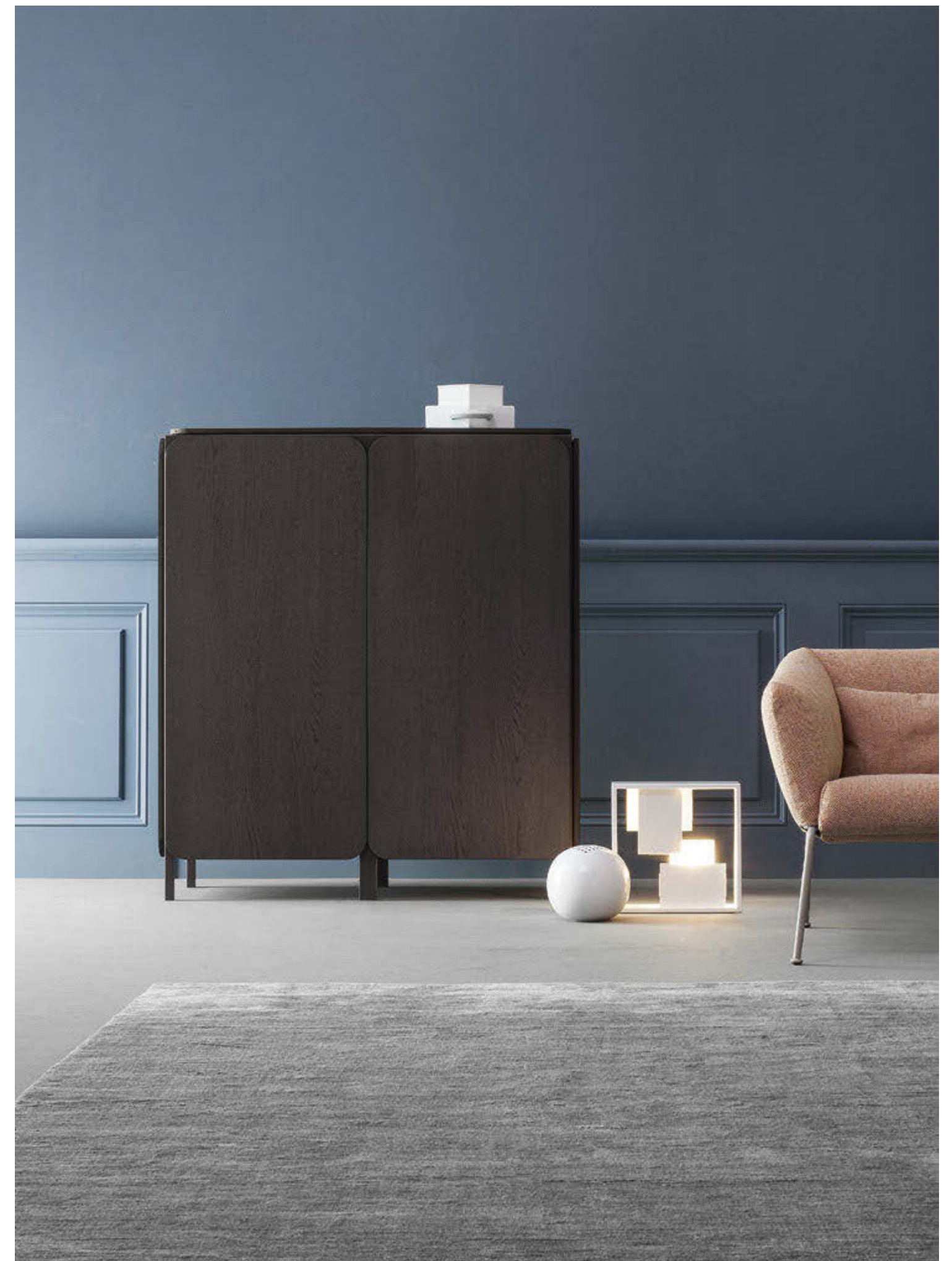



Frame Sideboard Alain Gilles
Credenza. Sideboard. Sideboard. Buffet.

Note Sideboard

Un oggetto d'arredo dalle forme geometriche semplici, ma con un carattere forte e originale. La madia Note si presenta come un parallelepipedo sospeso sostenuto da due assi verticali inclinate: un modo di evidenziarne la particolarità, affidata anche al contrasto dei colori. È possibile abbinarla alla libreria Note, per creare così un ambiente coordinato.

En An item of furniture with simple geometric shapes, but a strong and original character. The Note sideboard looks like a suspended parallelepiped supported by two vertical inclined axes: a way of highlighting its individuality, also offered by the colour contrasts. It can be combined with the Note bookcase, for creating a coordinated look.

De Einfache geometrische Formen bestimmen das ausdrucksstarke, originelle Design von Note. Das Sideboard präsentiert sich als schwebendes Parallelepiped, das von zwei leicht schrägen vertikalen Stützstreben in Position gehalten wird. Sie verstärken dessen einzigartigen Charakter ebenso wie der Kontrast der gewählten Farben. Darüber hinaus lässt sich das Sideboard Note auch schön mit dem gleichnamigen Bücherregal kombinieren – für eine ansprechend einheitliche Optik.

Fr Une pièce de mobilier aux formes géométriques simples, mais avec un caractère fort et original. Le buffet Note se présente comme un parallélépipède suspendu par deux axes verticaux inclinés : une façon d'en souligner son originalité renforcée par ailleurs par le contraste des couleurs. Possibilité de l'associer à la bibliothèque Note pour créer un espace coordonné.

Note Sideboard Mario Mazzer
Credenza. Sideboard. Sideboard. Buffet.

Noce Canaletto / marrone
Walnut Canaletto / brown
Nussbaum Canaletto / Braun
Noyer Canaletto / marron

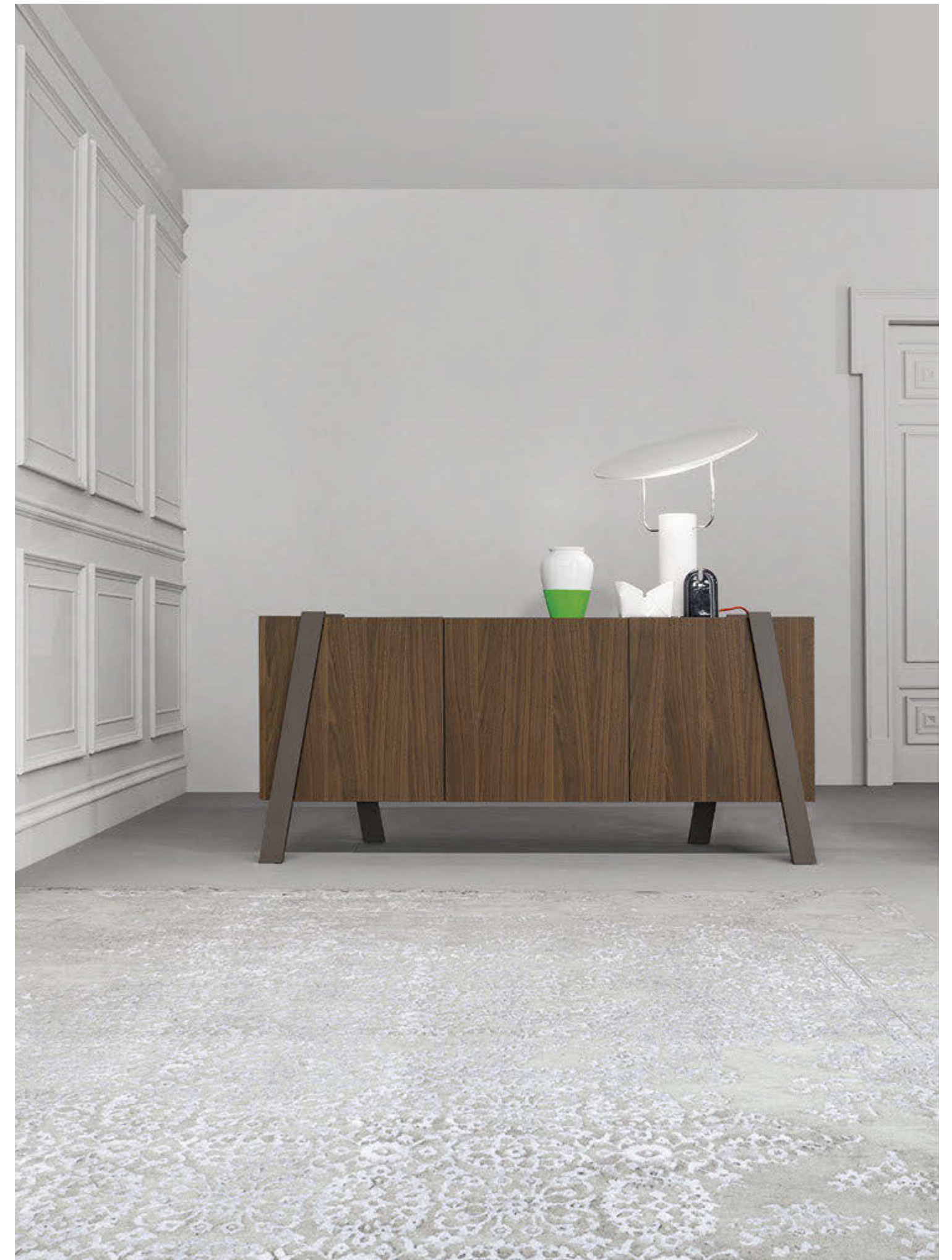



Note Sideboard Mario Mazzer
Credenza. Sideboard. Sideboard. Buffet.

Rovere termotrattato / marrone
Heat-treated oak / brown
Thermo-behandelte Eiche / Braun
Rouvre traité thermiquement / marron



Doppler Sideboard

Le madie Doppler sono caratterizzate da un particolare effetto ottico: la combinazione di diversi motivi grafici dai colori accesi crea l'illusione di piani sovrapposti, mentre in realtà le ante sono formate da un unico piano. L'apertura asimmetrica delle ante rappresenta un ulteriore segno di originalità di un prodotto che, disponibile in due dimensioni (Low, High), è perfetto per arredare la zona living.

En The Doppler sideboards feature a special optical effect. The combination of different graphic patterns in bright colours creates the illusion of overlapping surfaces, but in actual fact the doors are made up of a single surface. The asymmetric opening of the doors is a further sign of the originality of a product which, available in two dimensions (Low, High), is perfect for furnishing the living area.

De Die Sideboards Doppler überraschen mit einer optischen Täuschung. Durch die Kombination verschiedener knallbunter Muster entsteht die Illusion mehrerer einander überlagernder Ebenen, obwohl die Türen in Wirklichkeit aus jeweils nur einem Paneel bestehen. Besonders originell: deren asymmetrischen Anordnung. Erhältlich in zwei Größen (Low, High) eignet sich Doppler perfekt zur Gestaltung von Wohnbereichen.

Fr Les buffets Doppler sont caractérisés par un effet optique particulier : la combinaison des différents motifs graphiques aux couleurs vives donne l'illusion de plans superposés, alors que les portes sont en fait constituées d'un seul et unique panneau. L'ouverture asymétrique des portes de porte renforce l'originalité de ce produit. Disponible en deux formats (Low et High), il est idéal pour la zone living.

Doppler Sideboard Giuseppe Viganò
Credenza. Sideboard. Sideboard. Buffet.





Doppler Sideboard Giuseppe Viganò
Credenza. Sideboard. Sideboard. Buffet.





Doppler Sideboard Giuseppe Viganò
Credenza. Sideboard. Sideboard. Buffet.

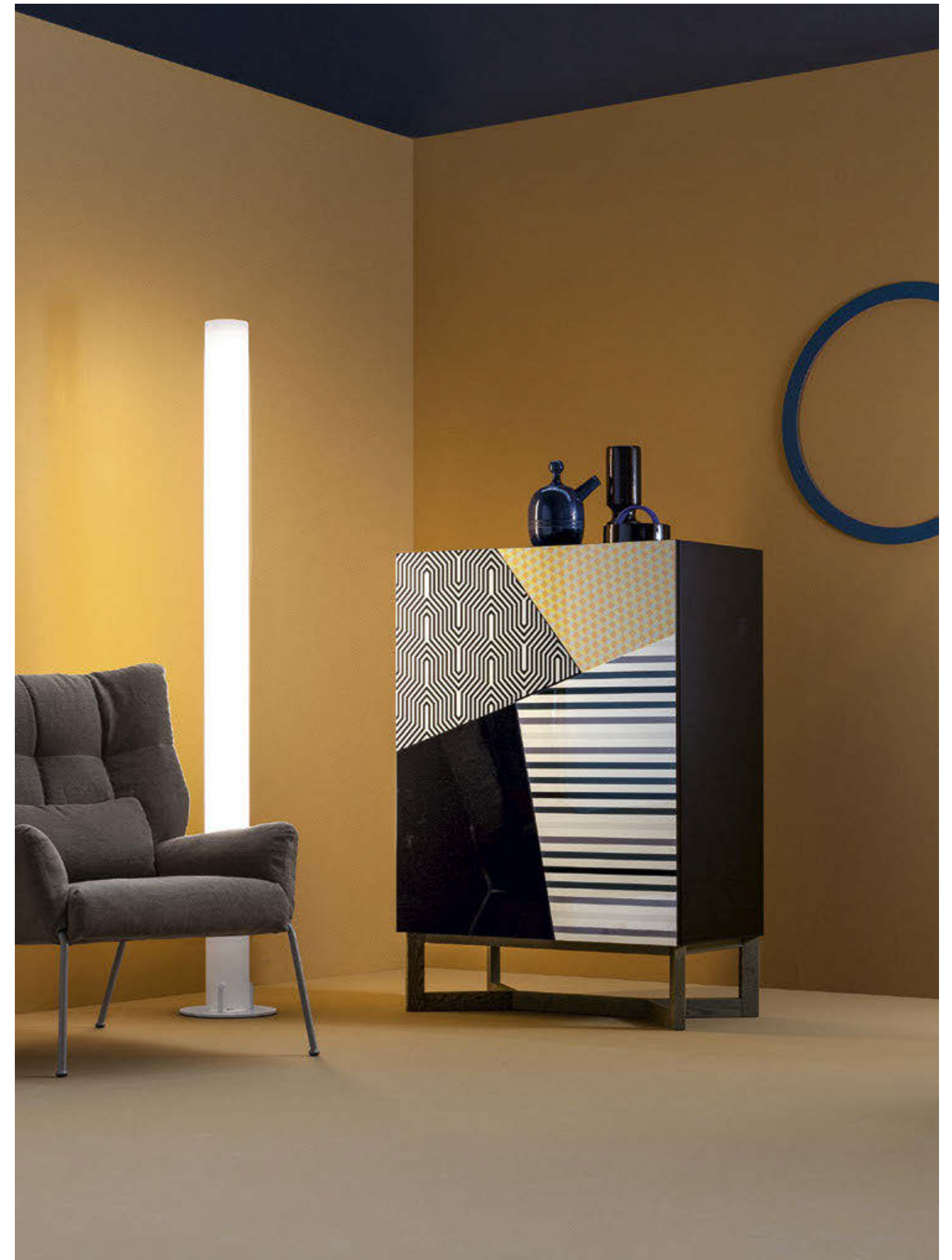

Sunrise

Un progetto ad alto contenuto tecnico, dalla massima funzionalità. Sunrise è una madia a tre o quattro ante a sviluppo orizzontale, di assoluta linearità formale. È realizzata in legno, con i ripiani interni in cristallo. Disponibile anche nella versione Sunrise Light, con luce posta nel vano a vista.

En A design with high technical content, offering utmost functionality. Sunrise is a sideboard with three or four doors fitted side by side, with absolutely formal linearity. It is made of wood, with internal crystal shelves. It is also available in the Sunrise Light version, with a light fitted in the visible compartment.

De Hochtechnisches Design, maximale Funktionalität. Sunrise ist ein Sideboard mit drei oder vier horizontal angeordneten Türen und bestechend linearer Optik. Der Korpus besteht aus Holz, die Regalböden aus Glas. Erhältlich auch in der Ausführung Sunrise Light, mit Beleuchtung im offenen Fach.

Fr Un petit concentré de technologie et de fonctionnalités. Sunrise est un buffet à trois ou quatre portes placées les unes à côté des autres, pour une linéarité absolue des formes. La structure est en bois, tandis que les rayonnages intérieurs sont en cristal. Le buffet est également proposé dans la version Sunrise Light, avec un éclairage situé dans le compartiment ouvert.

Sunrise Light Gino Carollo
Credenza. Sideboard. Sideboard. Buffet.





Sunrise Light Gino Carollo
Credenza. Sideboard. Sideboard. Buffet.



Spring

Spring è una credenza caratterizzata da una forma trapezoidale, che si sviluppa in orizzontale. Grazie alla forza delle forme geometriche e all'energia del colore, Spring conferisce un tocco di originalità ad ogni ambiente.

En Spring is a sideboard with a trapezoidal shape, which extends horizontally. The strength of Spring's geometric shapes and the energy of its colour give all rooms a touch of originality.

Fr Spring est un buffet horizontal de forme trapézoïdale. Grâce à l'élégance des formes géométriques et à l'énergie de la couleur, Spring apporte à chaque pièce sa touche d'originalité.

De Spring ist ein trapezförmiges Sideboard in horizontaler Ausführung. Mit seiner ausdrucksstarken geometrischen Form und seinen kräftigen Farben setzt Spring in jedem Raum originelle Akzente.



Spring Gino Carollo
Credenza. Sideboard. Sideboard. Buffet.

Summer

Summer è una credenza che riprende le geometrie e l'energia cromatica di Spring e le reinterpreta in modo originale: la forma trapezoidale si sviluppa in verticale. È dotata, inoltre, di uno spazio a giorno nella parte superiore e di un cassetto e può essere usata anche come scrittoio.

En Summer is a sideboard which reflects the geometries and chromatic energy of Spring, reinterpreting them in an original way as its trapezoidal shape extends vertically. It also has a doorless space at the top and a drawer and can also be used as a desk.

De Das Sideboard Summer greift die geometrischen Formen und intensiven Farben von Spring auf, um sie auf originelle Weise neu zu interpretieren: Das „Trapez“ wird kurzerhand in die Vertikale gebracht. Darüber hinaus verfügt Summer im oberen Bereich über ein offenes Regal sowie eine Lade und kann auch als Schreibtisch genutzt werden.

Fr Summer est un buffet qui reprend la géométrie et l'énergie chromatique de Spring pour les réinterpréter de manière originale avec une forme trapézoïdale verticale. Doté d'une étagère ouverte dans la partie supérieure et d'un tiroir, il peut également servir de secrétaire.

Summer Gino Carollo
Credenza. Sideboard. Sideboard. Buffet.





Summer Gino Carollo
Credenza. Sideboard. Sideboard. Buffet.

Monforte

Monforte è una collezione di tavolini disponibile in diverse forme, misure e materiali. Le gambe in legno massello sono il tratto distintivo di questa famiglia di tavolini dal design lineare ed equilibrato che si trova a proprio agio sia nella zona living sia nella zona notte.

En Monforte is a coffee table collection available in different shapes, sizes and materials. The solid wood legs are the distinctive feature of this family of coffee tables with a linear and balanced design which is at ease both in the living room and the bedroom.

De Die Kollektion Monforte umfasst eine Reihe von Couchtischen in unterschiedlichen Formen, Größen und Materialien. Die Beine aus massivem Holz sind dabei das gemeinsame Merkmal der Serie. Ihr lineares und harmonisches Design fügt sich schön sowohl in den Wohn- als auch Schlafbereich.

Fr Monforte est une collection de tables basses de formes, dimensions et matériaux différents. Les pieds en bois massif sont la caractéristique de cette famille de tables basses au design linéaire et équilibré qui trouvent naturellement leur place aussi bien dans la zone living que dans la zone nuit.



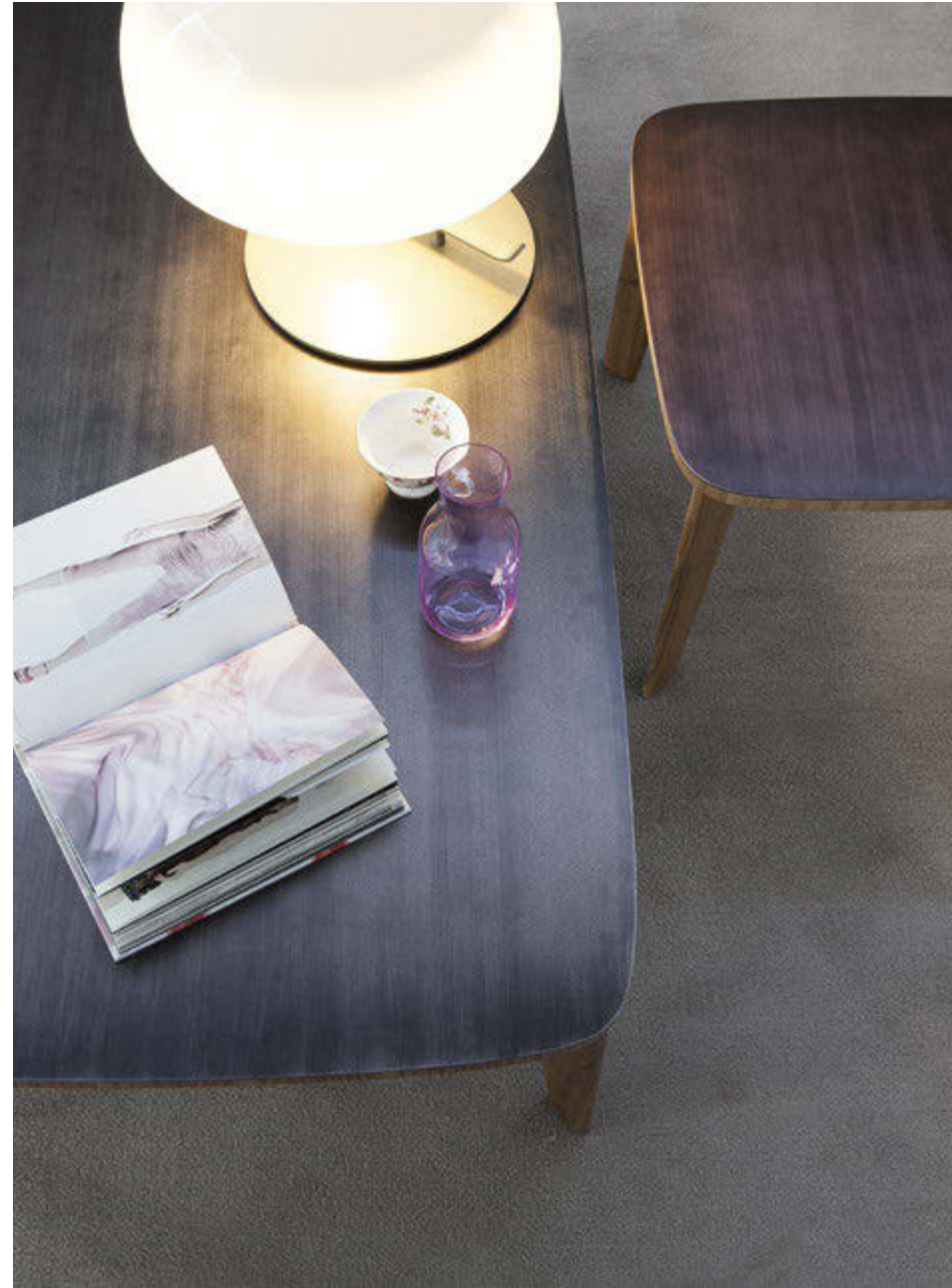

Monforte Mauro Lipparini
Tavolino. Coffee table. Couchtisch. Table basse.



Tie

Un effetto di assoluta leggerezza dato dai sottili piedi in lamiera di metallo piegato che sostengono il piano. Un design dal gusto vagamente retrò che lo rende un complemento decisamente originale. Il tavolino Tie è disponibile in tre altezze e nelle versioni con piano tondo o esagonale.

En An effect of absolute lightness which comes from the slim bent sheet metal feet, which support the top. A design with a vaguely retro flavour which makes it a decisively original accessory. The Tie table is available in three heights and in the versions with a round or hexagonal table top.

De Die langen, schlanken Beine aus gebogenem Blech tragen die Tischplatte, vermitteln dabei aber ein faszinierendes Gefühl von Leichtigkeit. Das Design von Tie erinnert ein wenig an klassische Retro-Möbel und verleiht dem Couchtisch damit eine unbestritten originelle Optik. Tie ist in drei Höhen mit runder oder sechseckiger Tischplatte erhältlich.

Fr Un plateau soutenu par des pieds fins en métal plié pour un effet de légèreté absolue. Un design à l'esprit rétro pour un complément absolument original. La table basse Tie est disponible en trois hauteurs, avec plateau rond ou hexagonal.

Tie Mauro Lipparini
Tavolino. Coffee table. Couchtisch. Table basse.





Tie Mauro Lipparini
Tivolino. Coffee table. Couchtisch. Table basse.

Doppler

Con l'uso di numerosi colori e forme e con la sovrapposizione di motivi grafici diversi, i tavolini della collezione Doppler comunicano un'idea di vivacità e dinamismo. Possono essere usati singolarmente o in gruppo oppure abbinati alla credenza Doppler.

En Using numerous colours and shapes with overlapping different graphic patterns, the coffee tables in the Doppler collection create an idea of vivacity and dynamism. They can be used individually or in a group or can be combined with the Doppler sideboard.

De Mit ihren zahlreichen Farben und Formen und den verschiedenen, einander überlappenden Mustern wirken die Couchtische der Kollektion Doppler außergewöhnlich lebendig und dynamisch. Die Modelle können einzeln, in Gruppen oder in Kombination mit dem Sideboard Doppler eingesetzt werden.

Fr Les tables basses de la collection Doppler se distinguent par leur esthétique basée sur l'utilisation d'un grand nombre de couleurs, formes et motifs graphiques encastrés les uns dans les autres, transmettant ainsi une idée de bonne humeur et de dynamisme. Elles peuvent être utilisées simples ou en composition, ou bien encore en association avec le buffet Doppler.



Doppler Giuseppe Viganò
Tavolino. Coffee table. Couchtisch. Table basse.

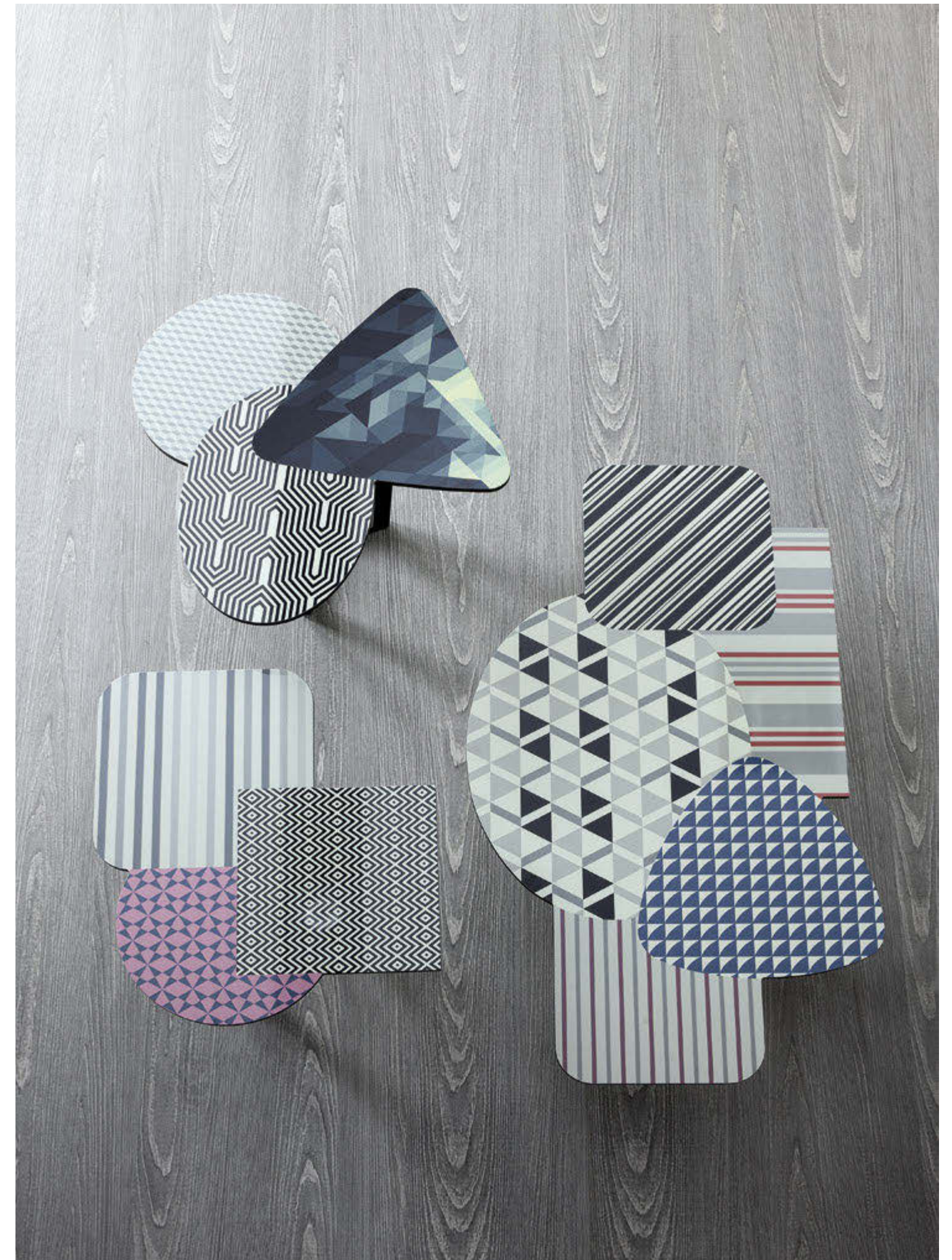

Fard

Rigorosi e geometrici nelle linee, eleganti e ricercati nell'utilizzo dei materiali, Fard è una famiglia di tavolini che possono convivere perfettamente per formare originali composizioni oppure essere scelti singolarmente nell'arredo di un ambiente, o abbinati a divani o letti.

En With rigorous and geometric lines and elegant and refined materials, Fard is a family of coffee tables that can perfectly live together forming original compositions or be chosen individually for furnishing a room,

De Strenge, geometrische Linien kombiniert mit eleganten, ausgewählten Materialien. Die Couchtische der Serie Fard eignen sich ideal für originelle Gruppenkompositionen, machen aber auch einzeln oder neben einem Sofa oder Bett schöne Figur.

Fr Des lignes géométriques strictes et un choix de matériaux sophistiqués et élégants pour Fard, une famille de tables basses faciles à associer pour créer des compositions originales ou à utiliser seules dans une pièce, ou à proximité d'un canapé ou d'un lit.

Fard Giuseppe Viganò
Tavolino. Coffee table. Couchtisch. Table basse.



Bend

Una sottile lastra di acciaio di forma ottagonale piegata e con gli angoli arrotondati; un piano in massello di legno caratterizzato da un alto spessore: Bend è un tavolino longitudinale che, grazie alla disposizione dei piani su due livelli, consente il contenimento di oggetti sulla base.

En A thin slab of steel in a bent octagonal shape with rounded corners; a solid wood top which is distinctively thick. Bend is a longitudinal table whose two-tier table top layout makes it possible to store items in the compartment.

De Eine dünne, achteckige Stahlplatte, aufgebogen und mit abgerundeten Kanten. Eine starke Tischplatte aus massivem Holz. Der längliche Couchtisch Bend verfügt über zwei Ebenen und bietet damit nützlichen Stauraum.

Fr Une fine plaque de forme octogonale en acier, pliée et aux angles arrondis, un plateau épais en bois massif : Blend est une table basse de forme longitudinale qui grâce à l'organisation des plateaux sur deux niveaux offre un espace de rangement pour des objets dans le compartiment.



Bend Mauro Lipparini
Tavolino. Coffee table. Couchtisch. Table basse.





Bend Mauro Lipparini
Tavolino. Coffee table. Couchtisch. Table basse.

Voilà

Voilà è un originale tavolino da salotto in metallo verniciato caratterizzato dalla forza espressiva dei materiali e dalla modernità delle scelte progettuali. Nel complesso, dà alla zona living un effetto di dinamicità e rigore.

En Voilà is an original painted metal coffee table marked by the expressive strength of its materials and the modernity of the design choices. Overall, it gives the living area a dynamic and rigorous effect.

De Der originelle Couchtisch Voilà ist aus lackiertem Metall gefertigt und besticht durch ausdrucksstarke Materialien und überzeugend modernes Design. Gesamt betrachtet verleiht er dem Wohnraum zugleich Dynamik wie eine gewisse Strenge.

Fr Originale, Voilà est une table basse de salon en métal verni, caractérisé par la force expressive des matériaux et la modernité des choix conceptuels. Dans l'ensemble, elle apporte à la zone living une touche de dynamisme et de rigueur.



Voilà Max Piva
Tavolino. Coffee table. Couchtisch. Table basse.



Planet

Un sicuro protagonista dell'arredo dell'ambiente domestico: con la sua forma emisferica, Planet è una collezione di tavolini dal forte impatto estetico. Viene realizzato in due dimensioni: Planet e Big Planet.

La collezione di tavolini Planet viene realizzata anche nelle varianti Planet Light e Big Planet Light con illuminazione interna: una scelta che ne esalta funzionalità, eleganza e modernità.

En A safe focal point for furnishing the home. With its hemispherical shape, Planet is a collection of coffee tables with a striking aesthetic impact. It is available in two sizes: Planet and Big Planet. The Planet coffee table collection is also available in the Planet Light and Big Planet Light variations with internal lighting, a choice that exalts its functionality, elegance and modernity.

De Ein garantierter Blickfang im Wohnbereich. Das halbkugelförmige Design der Couchtische Planet fesselt mit seiner starken optischen Wirkung. Erhältlich in zwei Größen, Planet und Big Planet. Die Couchtische der Kollektion Planet werden auch in den Ausführungen Planet Light und Big Planet Light mit integrierter Beleuchtung angeboten und präsentieren sich damit noch funktioneller, noch eleganter, noch moderner.

Fr Une pièce de mobilier qui sait se faire remarquer dans un intérieur. Caractérisée par une forme semi-sphérique, Planet est une collection de tables basses au fort impact esthétique. Planet existe en deux versions : Planet et Big Planet. Les tables basses Planet existent également dans les variantes Planet Light et Big Planet Light, avec un éclairage intérieur : une option qui enrichit son côté fonctionnel tout en apportant une touche d'élégance et de modernité.



Planet Gino Carollo
Tavolino. Coffee table. Couchtisch. Table basse.





Planet Light Gino Carollo
Tavolino. Coffee table. Couchtisch. Table basse.



Big Planet Gino Carollo
Tavolino. Coffee table. Couchtisch. Table basse.

Orion

I tubolari d'acciaio che formano la base di Orion si ispirano alle orbite circolari compiute dalle stelle durante la rotazione terrestre. Un nome e un'immagine di grande forza suggestiva, per una collezione di tavolini affascinante ed evocativa.

En The steel tubes that form the base of Orion are inspired by the circular orbits of the stars during the earth's rotation. A name and image with striking force, for a charming and evocative collection of coffee tables.

De Die Stahlrundrohre des Gestells von Orion erinnern an die Umlaufbahnen der Sterne um die sich drehende Erde. Ein Name und ein Bild von starker suggestiver Wirkung für eine Kollektion von ebenso faszinierenden und einzigartigen Couchtischen.

Fr La structure tubulaire en acier qui forme la base d'Orion s'inspire des orbites circulaires des étoiles pendant leur rotation autour de la terre. Un nom et une image au grand pouvoir évocateur pour cette collection de tables basses au charme indéniabile.



Orion Jarrod Lim
Tavolino. Coffee table. Couchtisch. Table basse.



Cosmos

Cosmos è un tavolino da salotto che, per la pienezza dei suoi volumi, è da collocare in posizione di rilievo nella zona giorno. È disponibile anche nella versione Cosmos Light, con illuminazione interna e piano in cristallo.

En Cosmos is a coffee table whose full volumes make it ideal for placing in prime position in the living area. It is also available in the Cosmos Light version, with internal lighting and a crystal top.

De Der Couchtisch Cosmos ist mit seiner voluminösen Präsenz in entsprechend zentraler Position im Wohnzimmer am besten aufgehoben. Erhältlich auch in der Ausführung Cosmos Light mit integrierter Beleuchtung und Tischplatte aus Glas.

Fr Cosmos est une table basse de salon qui, de par la plénitude de ses volumes, devra occuper une place de choix dans la zone jour. Disponible également, la version Cosmos Light avec éclairage interne et plateau en cristal.

Cosmos Gino Carollo
Tavolino. Coffee table. Couchtisch. Table basse.



Ribbon

Il fascino dei materiali prestigiosi, delle forme essenziali ma di grande impatto emozionale, di un'interpretazione progettuale originale. Ribbon è un tavolino con base quadrata in marmo di Carrara bianco opaco e top in cristallo curvato, disponibile in due diverse dimensioni.

En The charm of prestigious materials with essential shapes that have a strong emotional impact, with an original design interpretation. Ribbon is a coffee table with a square matt white Carrara marble base and a curved crystal top, available in two different sizes.

De Ribbon fasziniert mit hochwertigen Materialien, mit Formen, die trotz ihrer Schlichtheit emotional berühren, mit außergewöhnlichem Design. Der Couchtisch mit quadratischem Sockel aus mattem weißem Carrara-Marmor und Tischplatte aus gerundetem Glas ist in zwei Größen erhältlich.

Fr Le charme des matériaux nobles, des formes essentielles mais au fort impact émotionnel, et d'une interprétation conceptuelle originale. Disponible en deux formats différents, Ribbon est une table basse composée d'une base carrée en marbre de Carrare blanc mat et d'un plateau en cristal incurvé.



Ribbon Mauro Lipparini
Tavolino. Coffee table. Couchtisch. Table basse.



Mille Coffee

La trasparenza del piano in cristallo unito alla presenza numerosa delle gambe in acciaio, per garantire massima stabilità e coerenza visiva. Mille Coffee è un tavolino che ripropone le caratteristiche del tavolo Mille, a cui si ispira: sembra possedere tutta l'armonia e la dinamicità di un corpo trasparente in movimento.

En The transparency of the glass top along with the numerous steel legs, guarantee maximum stability and visual coherence. Mille Coffee is a coffee table that reflects the characteristics of the Mille table which inspired it: it seems to have all the harmony and dynamism of a transparent body in motion.

De Die Transparenz der Glasplatte wird hier gekonnt mit dem Bild der zahlreichen Tischbeine aus Stahl kombiniert um maximale Stabilität und eine ausgewogene Optik zu gewährleisten. Mille Coffee ist ein Kleintisch, die die Merkmale des Mille Tisches bietet: scheint in Bewegung die ganze Harmonie und Dynamik eines transparenten Körper zu besitzen.

Fr La transparence du plateau en cristal associée à la présence de nombreux pieds en acier garantit une stabilité optimale et une cohérence visuelle. Mille Coffee est une table basse qui reprend les caractéristiques de la table Mille dont elle est inspirée: elle semble posséder toute l'harmonie et le dynamisme d'un corps transparent en mouvement.



Mille Coffee Bartoli Design
Tavolino. Coffee table. Couchtisch. Table basse.

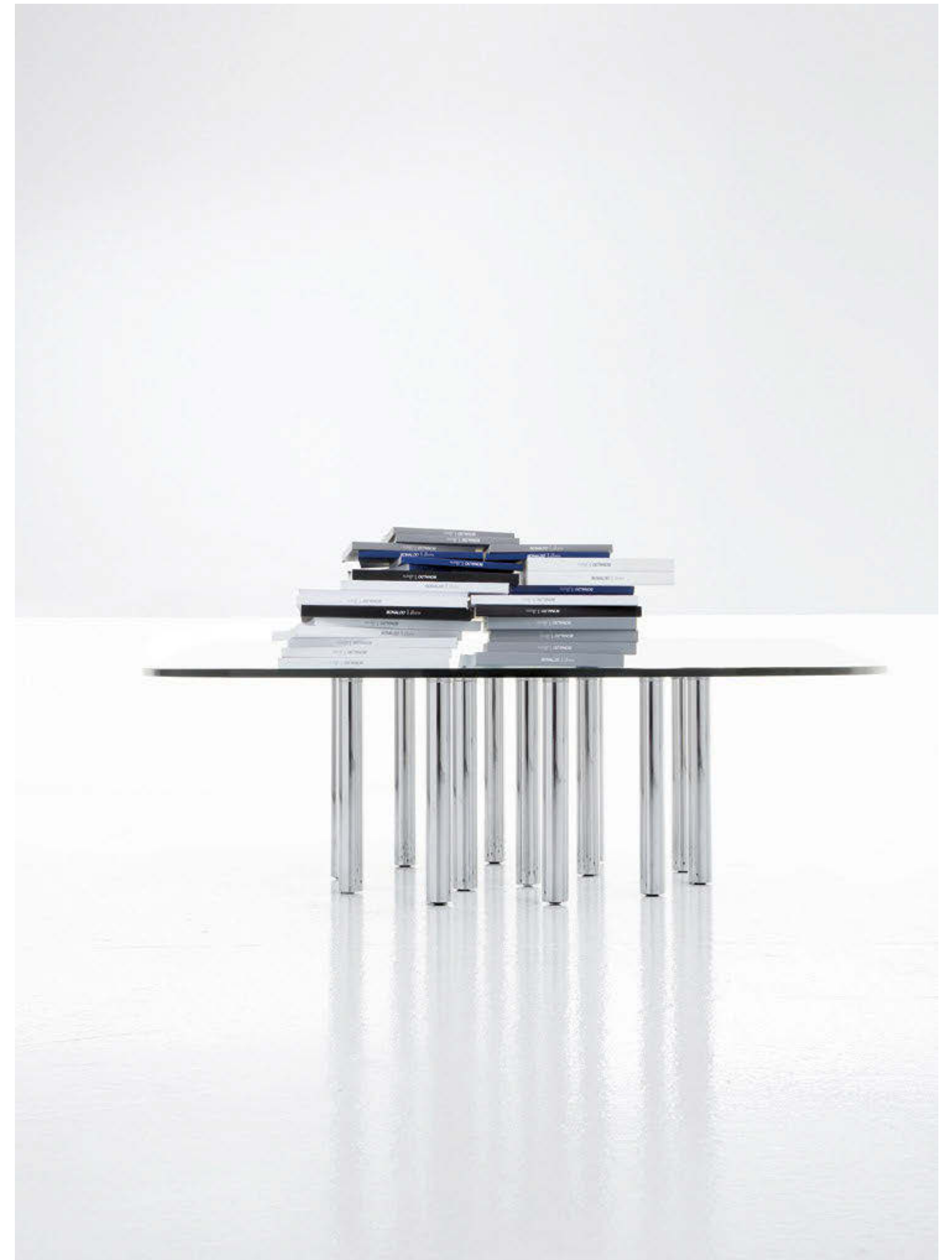

Folio

Il cristallo in forma pura e assoluta, quadrata o rettangolare: l'essenzialità del parallelepipedo come scelta di stile. Folio, un tavolino da salotto prezioso ed elegante, sia contenitore, sia piano d'appoggio.

En Crystal in its pure and absolute form, square or rectangular: the elemental appeal of the parallelepiped as a style choice. Folio, a prestigious and elegant coffee table, both a container and a display surface.

De Reines Glas in seiner schönsten Form. Ob rechteckig oder quadratisch, die schlichte Form des Quaders wird hier zum Stilbekenntnis. Hochwertig und elegant beglückt der Couchtisch Folio sowohl als Aufbewahrungslösung wie auch als Ablage.

Fr Le cristal dans sa forme la plus pure et absolue, à savoir carrée ou rectangulaire: le caractère essentiel du parallélépipède comme choix stylistique. Folio, une table basse précieuse et élégante qui servira au salon aussi bien comme surface d'appui que comme module de rangement.



Folio Gino Carollo
Tavolino. Coffee table. Couchtisch. Table basse.



Collage

Un oggetto dinamico e in perenne trasformazione: Collage è un'originale composizione di tavolini in metallo. Tutti i tavolini, tranne uno, sono uniti. Il tavolino tondo al centro fa da perno a tutti gli altri, che sono agganciati e si posizionano liberamente gravitando intorno al primo. Un tavolino extra, svincolato, può essere posizionato per ridisegnare la composizione.

En A dynamic, constantly transforming item: Collage is an original composition of metal coffee tables. All except one of the coffee tables are connected. The round coffee table in the middle acts as a hinge for all the others, which are attached and can be positioned freely around the first. An extra coffee table (free from the others) can be positioned to redesign the composition.

De Dynamisch und immer in Bewegung. Collage ist eine originelle Couchtischgruppe aus Metall. Bis auf einen sind alle Tische miteinander verbunden. Der runde Tisch in der Mitte dient zugleich als zentrale Achse für die anderen, die daran befestigt sind und sich frei im Kreis um ersteren herum anordnen lassen. Der separate Tisch kann unabhängig von den anderen aufgestellt werden und ermöglicht damit eine Vielzahl unterschiedlicher Zusammenstellungen.

Fr Un objet dynamique et en transformation perpétuelle: Collage est une composition originale de tables basses en métal. Toutes les tables basses, sauf une, sont unies. La table basse ronde au centre sert d'axe à toutes les autres, qui sont accrochées et se placent librement autour de la première. Une table basse supplémentaire, détachée, peut être ajoutée pour modifier le dessin de la composition.



Collage Alain Gilles
Tavolino. Coffee table. Couchtisch. Table basse.



Kadou Coffee

Kadou Coffee è un elegante tavolino che richiama le forme di una tradizionale composizione di fiori giapponese e racconta l'incontro tra cultura e tradizione orientali e know-how produttivo Made in Italy: il suo nome significa appunto "l'arte dei fiori". Il piano è in metallo verniciato; le gambe sono poste asimmetricamente rispetto a base e piano e sono realizzabili in numerosi colori. Kadou Coffee è disponibile in tre versioni, in cui varia l'altezza del tavolino e il diametro dei piani: Kadou Coffee high, Kadou Coffee middle e Kadou Coffee low.

En Kadou coffee is an elegant coffee table which recalls the shapes of a traditional composition of Japanese flowers and tells of the meeting between oriental culture and tradition and Italian production know-how. In fact, its name means "the art of flowers". The top is painted metal; the legs are placed asymmetrically in relation to the base and the top and can be made in various colours. Kadou Coffee is available in three versions, in which the height of the table and diameter of the tops vary: Kadou Coffee high, Kadou Coffee middle and Kadou Coffee low.

De Der elegante Couchtisch Kadou Coffee erinnert in seiner Form an traditionelle japanische Blumenkompositionen und erzählt von der Begegnung zwischen orientalischer Kultur und Tradition und technischem Know-how „made in Italy“. Tatsächlich bedeutet sein Name „Blumenkunst“. Die Tischplatte besteht aus lackiertem Metall, die asymmetrisch positionierten Beine verbinden Basis und Tischplatte und sind in zahlreichen farblichen Varianten verfügbar. Kadou Coffee ist in den drei Ausführungen High, Middle und Low mit unterschiedlichen Höhen und Plattendurchmessern erhältlich.

Fr Kadou Coffee est une élégante table d'appoint qui évoque les formes d'une composition traditionnelle de fleurs japonaises et raconte la rencontre entre la culture et la tradition orientale et le savoir-faire du Made in Italy. D'ailleurs, son nom signifie précisément « l'art des fleurs ». Le plateau est en métal verni ; les pieds sont placés de façon asymétrique par rapport à la base et au plan, et sont disponibles en différents couleurs. Kadou Coffee existe en trois versions où varient la hauteur et le diamètre de la table: Kadou Coffee high, Kadou Coffee middle et Kadou Coffee low.

Kadou Coffee Ryosuke Fukusada
Tavolino. Coffee table. Couchtisch. Table basse.





Kadou Coffee Ryosuke Fukusada
Tavolino. Coffee table. Couchtisch. Table basse.

Tectonic

Tectonic è un tavolino con piano in filo d'acciaio o in lamiera piena, che può essere utilizzato come pezzo unico o in gruppo, nella zona giorno o nella zona notte. Un oggetto che dà la possibilità di creare geometrie originali abbinando più elementi in maniera creativa.

En Tectonic is a coffee table with a steel wire or full sheet metal top, which can be used as a single item or in a group, in the living area or bedroom. An object that gives you the chance to create original geometric shapes by combining several elements creatively.

De Der Kleintisch Tectonic überrascht mit einer Tischplatte aus Stahldraht oder geschlossenem Blech und kann sowohl einzeln als auch in Gruppen im Wohn- oder Schlafbereich verwendet werden. Durch kreatives Kombinieren mehrerer Tische lassen sich zudem originelle geometrische Zusammenstellungen arrangieren.

Fr Tectonic est une table basse dotée d'un plateau en fil d'acier ou en tôle pleine pouvant être utilisée seule ou en composition, aussi bien dans la zone jour que dans la zone nuit. Un objet qui offre la possibilité de créer des géométries originales en combinant plusieurs éléments d'une façon créative.



Tectonic Alain Gilles
Tavolino. Coffee table. Couchtisch. Table basse.



Icosì

Icosì è un tavolino con struttura geometrica composta da fili d'acciaio, curvati e verniciati. Un'idea progettuale fondata sul principio della leggerezza e della versatilità: può essere utilizzato come pezzo unico o in gruppo, nella zona giorno o nella zona notte, in ambiente domestico o nel settore contract.

En The Icosì coffee table has a geometrical frame consisting of curved, painted steel wires. A design idea based on the principle of lightness and versatility: it can be used stand-alone or in compositions, in the living room or in the bedroom, at home or in the contract industry.

De Der Couchtisch Icosì besteht aus einem geometrischen Gestell aus gebogenen lackierten Stahldrähten. Sein Design basiert auf dem Konzept der Leichtigkeit und Vielseitigkeit und lässt sich entsprechend universell einsetzen – gleich ob einzeln oder in Gruppen, im Wohn- oder Schlafzimmer, im Privat- oder Objektbereich.

Fr Icosì est une table basse dotée d'une structure géométrique composée de fils d'acier, courbés et vernis. L'idée repose sur le principe de la légèreté et de la polyvalence, tant il est vrai que la table peut être utilisée seule ou en composition, aussi bien dans la zone jour que dans la zone nuit, dans un contexte domestique ou pour le contract.



Icosì Afroditi Krassa
Tavolino. Coffee table. Couchtisch. Table basse.



Vanity, Fortuny, Harry

Disponibili in due altezze, i tavolini in acciaio Vanity, Fortuny e Harry si differenziano tra loro nel disegno della colonna. Agili ed eclettici, sono caratterizzati da un fascino adatto sia alla zona giorno, sia alla zona notte.

En Available in two heights, the steel coffee tables Vanity, Fortuny and Harry differ in terms of their column design. Nimble and eclectic, they are distinguished by a charm that is suited both to the living room and the bedroom.

De Die in zwei Höhen erhältlichen Couchtische aus Stahl, Vanity, Fortuny und Harry, unterscheiden sich vor allem durch ihre unterschiedlich geformten Standsäulen. Dynamisch und vielseitig setzen sie sowohl im Wohn- als auch im Schlafbereich spannende Akzente.

Fr Disponibles en deux hauteurs, les tables d'appoint en acier Vanity, Fortuny et Harry se distinguent chacune par le design de la colonne. Gracieux, éclectiques et pleins de charme, ces modèles sont parfaits aussi bien dans la zone jour que dans la zone nuit.



Vanity, Fortuny, Harry Gino Carollo
Tavolini. Coffee tables. Couchtische. Tables basse.



Duffy

Trasformare una forma sinuosa ed equilibrata in un elegante elemento strutturale. Duffy è un tavolino di grande semplicità e praticità, adatto ad ambienti variamente connotati sul piano stilistico.

En The transformation of a sinuous and well-balanced shape into an elegant structural element. Duffy is a very simple and practical coffee table, suitable for rooms with various style connotations.

De Eine geschwungene, harmonische Form wird hier zum „tragenden“ Element. Überzeugend schlicht und praktisch fügt sich der Couchtisch Duffy problemlos in unterschiedliche Stilrichtungen ein.

Fr Transformer une forme sinueuse et équilibrée en un élégant élément structurel. Duffy est une table basse extrêmement simple et pratique, qui s'adapte parfaitement à différents styles d'intérieurs.

Duffy Mario Mazzer
Tavolino. Coffee table. Couchtisch. Table basse.



Muffin

La forma degli stampi del famoso dolce americano diventa un pezzo d'arredo che aggiunge un tocco di dolcezza ad ogni ambiente. Muffin è un complemento versatile: a seconda delle scelte, può fungere da seduta o da tavolino.

En The shape of the cases for this famous American cake has been turned into a piece of furniture which adds a touch of sweetness to every room. Muffin is a versatile accessory which, by choice, can be used as both a seat or a coffee table.

De Inspiriert vom Design der Backformen des berühmten amerikanischen Süßgebäcks wirkt Muffin in jedem Raum einfach süß. Darüber hinaus lassen sich die einzelnen Elemente vielseitig einsetzen – je nach Wunsch als Sitzgelegenheit oder Tischchen.

Fr Les caissettes à muffins, ces petits gâteaux typiquement américains, se transforment en pièces de mobilier pour ajouter une touche de douceur dans tous les espaces intérieurs. Polyvalent, Muffin peut servir soit de tabouret, soit de table.



Muffin / Muffin Light Ryosuke Fukusada
Tavolino. Coffee table. Couchtisch. Table basse.





Muffin Ryosuke Fukusada
Tavolino. Coffee table. Couchtisch. Table basse.



Arvo

Nella lingua finlandese Arvo significa 'valore': un nome importante per un tavolino connotato da una piacevole armonia ed eleganza. Arvo è formato da una base portaoggetti in materiale plastico e da un piano in cristallo.

En In Finnish, Arvo means "value" - an important name for a coffee table with a pleasant connotation of harmony and elegance. Arvo is comprised of a storage base made of plastic and a crystal top.

De "Arvo" bedeutet im Finnischen "Wert". Ein ausdrucksstarker Name für einen Couchtisch, der durch seine angenehm harmonische und elegante Form verzaubert. Arvo besteht aus einem Kunststoffgestell, das zugleich als Ablage dient, und einer Tischplatte aus Glas.

Fr En finlandais, Arvo signifie « valeur » : un nom important pour une table basse agréablement harmonieuse et élégante. Arvo est formée d'une base porte-objets en plastique et d'un plateau en cristal.

Arvo Mario Mazzer
Tavolino. Coffee table. Couchtisch. Table basse.



Pebble

Un sapiente equilibrio di volumi pieni e vuoti, una ricerca sui dettagli, sulle forme, sui materiali e sui colori. Pebble è un tavolino realizzato in polietilene che, grazie alla resistenza agli agenti atmosferici, può essere collocato anche all'esterno. Svolge anche la funzione di contenitore.

En A skilful balance of blocks and voids, painstaking care for details, for shapes, for materials and for colours. Pebble is a coffee table made of polyethylene. Thanks to its resistance to atmospheric agents, it can also be used outdoors. It can also be used as a container.

De Ein harmonisches Gleichgewicht von Fülle und Leere, sorgfältig eingesetzte Details, Formen, Farben und Materialien. Der Couchtisch Pebble besteht aus Polyethylen und lässt sich dank entsprechender Witterungsbeständigkeit auch gut im Freien aufstellen. Inklusive praktischem Stauraum.

Fr Un savant équilibre de volumes pleins et vides, une recherche poussée au niveau des détails, des formes, des matériaux et des couleurs. Pebble est une table basse réalisée en polyéthylène qui, grâce à son exceptionnelle résistance aux agents atmosphériques, permet une utilisation même en extérieur. Pebble peut également servir de module de rangement.



Pebble Matthias Demacker
Tavolino. Coffee table. Couchtisch. Table basse.



Pebble Pouf

Pebble è un pouf dalle forme morbide, come quelle dei sassi levigati dal mare trovati sulla spiaggia. Le aperture nella struttura hanno funzione estetica ma anche pratica, poiché il corpo stesso del pouf può contenere libri, riviste o altri oggetti di uso quotidiano.

En Pebble is a pouf with soft shapes, like those of the pebbles polished by the sea that you can find on the beach. The openings in the frame have both a styling and a practical function, since the body of the pouf itself can house books, magazines or other everyday items.

De Pebble ist ein Pouf mit weichen Formen, die an vom Meer rund gewaschene Steine am Strand erinnern. Seine Öffnungen haben zugleich eine ästhetische wie auch praktische Funktion. Dank ihnen können im Inneren des Poufs Bücher, Zeitschriften und andere Gegenstände des täglichen Gebrauchs aufbewahrt werden.

Fr Pebble est un pouf aux formes arrondies, comme celles des galets polis par la mer que l'on trouve sur la plage. Les ouvertures dans la structure ont une fonction non seulement esthétique mais aussi pratique puisque le corps du pouf peut contenir des livres, des revues ou d'autres objets d'usage quotidien.



Pebble Pouf Matthias Demacker
Pouf



Magazine Bag

Un modo originale di interpretare il portariviste: Magazine Bag è caratterizzato da un design ergonomico ed ha la forma di un tradizionale cesto di fiori giapponese. Prodotto in metallo verniciato, è disponibile in numerose varianti cromatiche e tre diverse dimensioni: small, medium, large.

En An original way of interpreting the magazine rack: Magazine Bag has an ergonomic design and the shape of a traditional Japanese flower basket. Made of painted metal, it is available in numerous colour variations and three different sizes: small, medium and large.

De Der etwas andere Zeitschriftenständer: Magazine Bag besticht durch sein ergonomisches Design, dessen Form an einen traditionellen japanischen Blumenkorb denken lässt. Gefertigt aus lackiertem Metall, erhältlich in zahlreichen farblichen Varianten in den drei Größen Small, Medium und Large.

Fr Une façon originale d'interpréter le porte-magazines. Magazine Bag est caractérisé par un design ergonomique et se présente comme un panier japonais traditionnellement utilisé pour les fleurs. Fabriqué en métal verni, il existe en de nombreuses versions chromatiques et trois formats différents : small, medium et large.



Magazine Bag Ryosuke Fukusada
Portariviste. Magazine rack. Zeitschriftenständer. Porte-revues.



small medium large



Magazine Bag Ryosuke Fukusada
Portariviste. Magazine rack. Zeitschriftenständer. Porte-revues.

April, May, June

Un nuovo concetto, un design deciso per un'innovativa modularità. Un sistema di piani d'appoggio dalla forte personalità: non solo libreria, ma oggetto che si presta a personali interpretazioni d'utilizzo. April, May e June possono essere utilizzati abbinati l'uno all'altro oppure usati singolarmente, adattandosi alla perfezione in ogni ambiente della casa, dalla zona giorno, alla zona notte, al bagno.

En A new concept, a decisive design for an innovative modular system. A display with a strong personality - not only a bookcase, but an item that lends itself to personal interpretations of use. April, May and June can be used in combination with one another or individually, adapting to any interior décor to perfection, from the living area to the bedroom or the bathroom.

De Ein neues Konzept mit entschlossenem Design und innovativem modularem Aufbau. Ein Ablagesystem mit ausdrucksstarker Persönlichkeit. Nicht nur ein einfaches Bücherregal also, sondern vielmehr ein Aufbewahrungssystem, das den Benutzer dazu einlädt, sich selbst individuelle Einsatzmöglichkeiten einfallen zu lassen. April, May und June können in Kombination oder als einzelne Elemente genutzt werden und eignen sich perfekt für alle Bereiche in Haus und Wohnung, für Wohn- und Schlafzimmer ebenso wie für Bäder.

Fr Un nouveau concept, un design affirmé pour une modularité innovante. Un système d'étagères à la forte personnalité. Bibliothèque oui, mais pas seulement, car ce produit se prête à différentes interprétations personnelles quant à son utilisation. April, May et June peuvent être utilisés combinés l'un à l'autre ou bien séparément et s'adaptent à la perfection à toutes les pièces de la maison (zone jour, zone nuit, salle de bains).

April, May, June Gino Carollo
Piani appoggio. Shelving units. Ablagesysteme. Plans d'appui.





June

April

May

Note

Un'interpretazione originale della libreria, un pentagramma dove le note sono i libri che offrono l'immagine di una personale melodia. La libreria Note è visivamente caratterizzata dalla rilevanza degli elementi verticali, disposti in modo obliquo. Abbinabile a Note Sideboard.

En An original interpretation of the bookcase, a pentagram where the notes are the books that offer the image of a personal melody. The Note bookcase is visually characterized by the significance of the vertical elements, arranged obliquely. Can be combined with the Note Sideboard.

De Ein Bücherregal der etwas anderen Art: ein Notenliniensystem, in dem die Noten von Büchern dargestellt werden, die die Notation einer persönlichen Melodie abbilden. Optisch kennzeichnen das Bücherregal Note außerdem die vertikalen, auffallend schrägen Stützstreben. Schön kombinierbar mit dem gleichnamigen Sideboard.

Fr Une interprétation originale du meuble de bibliothèque, une portée musicale où les notes sont les livres qui offrent ainsi l'image d'une mélodie toute personnelle. Visuellement, la bibliothèque Note est caractérisée par la prédominance des éléments verticaux disposés de manière oblique. Peut être associée à Note Sideboard.

Note Mario Mazzer
Libreria. Bookcase. Bücherregal. Étagère.





Note Mario Mazzer
Libreria. Bookcase. Bücherregal. Étagère.

comb. 1



Note Mario Mazzer
Libreria. Bookcase. Bücherregal. Étagère.

comb. 3

Up and Down

Un disegno grafico che esalta la profondità dei volumi e che sembra quasi variare al mutare del punto di vista. Up and Down è una libreria da parete composta da una struttura in legno laccato e da ripiani in cristallo. È disponibile anche nella versione con luce (Up and Down Light).

En A graphic design that emphasizes the depth of the volumes and that appears almost as if it changes according to your point of view. Up and Down is a wall-mounted bookcase comprising a lacquered wood structure and crystal shelves. It is also available in the version fitted with a light (Up and Down Light).

Fr Un design graphique qui exalte la profondeur des volumes et qui semble varier en fonction du point de vue. Up and Down est une bibliothèque murale composée d'une structure en bois laqué et d'étagères en cristal. Il existe également une version avec éclairage (Up and Down Light).

De Das grafisch anmutende Design betont die Tiefenwirkung der beiden Elemente und scheint sich zugleich je nach Blickwinkel zu ändern. Das Wandregal Up and Down besteht aus einem Korpus aus lackiertem Holz und Ablagen aus Glas. Erhältlich auch in der Ausführung mit Beleuchtung (Up and Down Light).

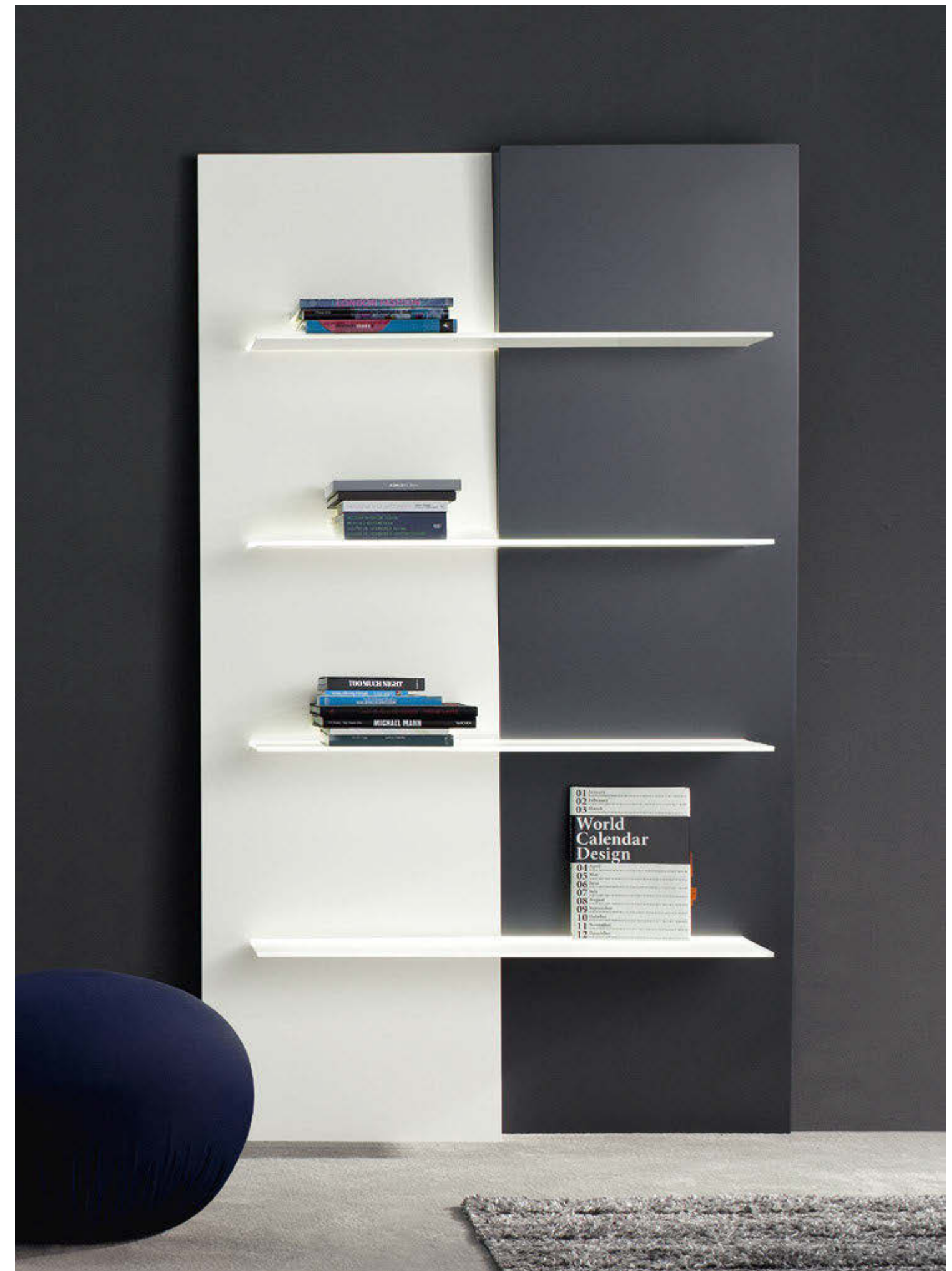

Up and Down Light Andrea Lucatello
Libreria. Bookcase. Bücherregal. Étagère.

Fun

Massima libertà compositiva e modernità di progetto: Fun è una libreria componibile fianco a fianco che può essere posizionata a muro oppure a centro stanza. L'organizzazione apparentemente irregolare degli spazi, nell'alternanza di vuoti e pieni, crea un originale effetto dinamico. Fun è disponibile in varie dimensioni, nelle varianti: Fun, Fun 2, Fun 3.

En Maximum composition freedom and design modernity - Fun is a modular side-by-side bookcase which can be wall-mounted or free-standing. The apparently irregular layout of the storage space - in an alternation of blocks and voids - creates an original dynamic effect. Fun is available in various dimensions in the following variations: Fun, Fun 2, Fun 3.

De Maximale Gestaltungsfreiheit und modernes Design. Das individuell zusammenstellbare Bücherregal Fun kann sowohl direkt an der Wand als auch in der Mitte des Raums aufgestellt werden. Die scheinbar unregelmäßige Anordnung der einzelnen Fächer, das Wechselspiel an leeren und vollen Flächen, verleiht dem Regalsystem dabei eine originelle optische Dynamik. Erhältlich in unterschiedlichen Größen in den Ausführungen Fun, Fun 2, Fun 3.

Fr Liberté totale pour la composition et modernité, tels sont les mots d'ordre qui ont accompagné ce projet de bibliothèque. Fun est composée de modules qui se positionnent les uns à côté des autres, contre un mur ou au centre d'une pièce. L'organisation apparemment irrégulière des espaces, en alternant des vides et des pleins, crée un effet original et dynamique. Fun est disponible en différentes dimensions dans les variantes suivantes: Fun, Fun 2, Fun 3.

Fun Gino Carollo
Libreria. Bookcase. Bücherregal. Étagère.



Cubic

Il nome enfatizza la forma: Cubic è una libreria fissa o girevole che rappresenta una nuova interpretazione progettuale della libreria. Cubic è non solo comodo contenitore, ma anche oggetto decorativo adatto anche agli spazi più ristretti.

En Its name emphasizes its shape. Cubic is a fixed or rotating bookcase that represents a new design interpretation of the bookcase. Cubic is not only a container, but also a decorative item which is suitable even in the most confined spaces.

De Wie der Name, so die Form. Das wahlweise feststehende oder drehbare Bücherregal Cubic präsentiert sich als gelungene Neuinterpretation des klassischen Regals. Cubic dient damit nicht nur zur Aufbewahrung, sondern überzeugt zugleich als dekoratives Wohnaccessoire mit minimalem Platzbedarf.

Fr Le nom souligne la forme : Cubic est une bibliothèque fixe ou tournante qui représente une nouvelle interprétation du concept de bibliothèque. Plus qu'un espace pratique de rangement, la bibliothèque est aussi un objet de décoration adapté même aux espaces les plus restreints.



Cubic Gino Carollo
Libreria. Bookcase. Bücherregal. Étagère.

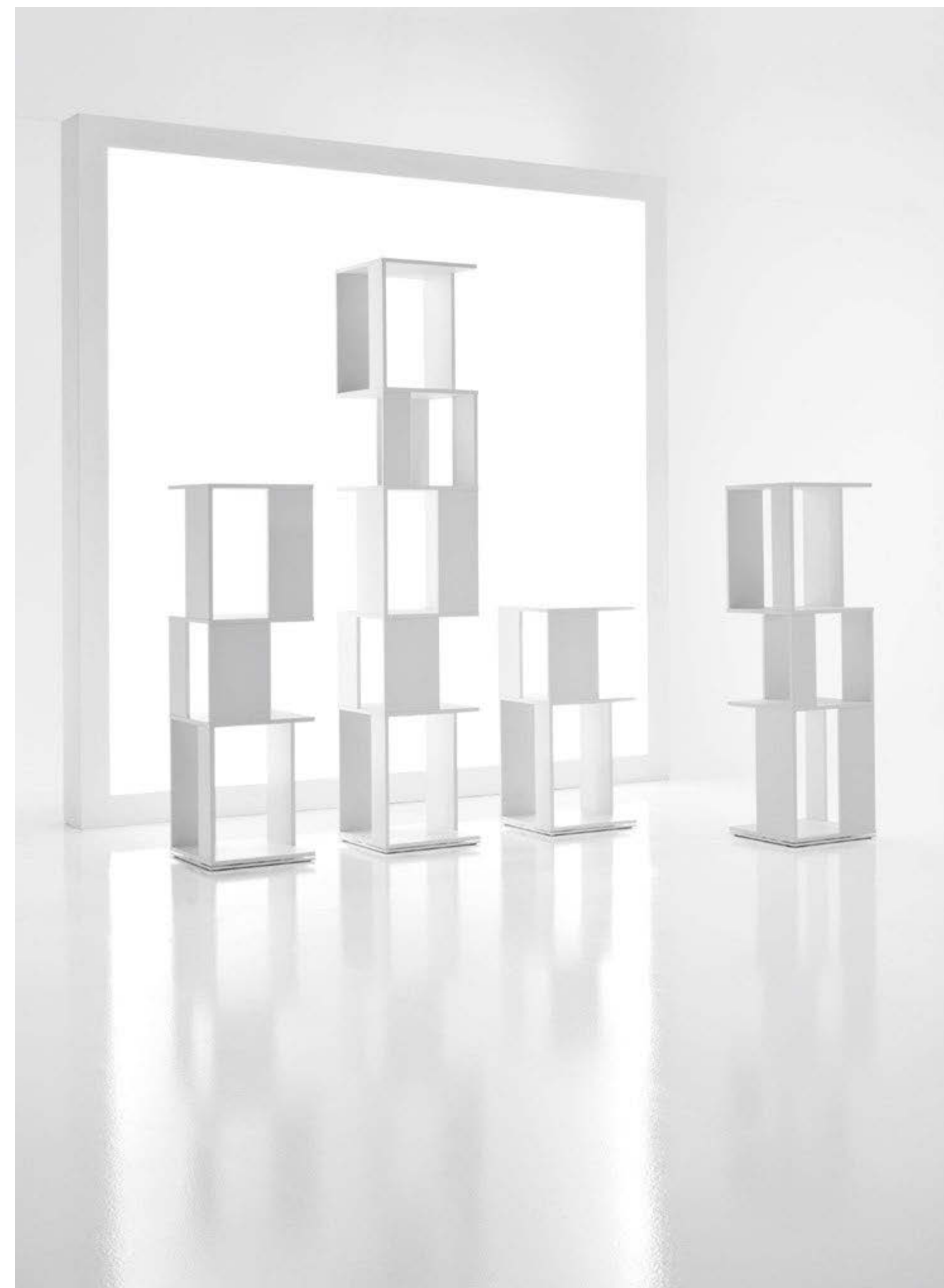

Cubic Glass

Un'idea progettuale che concentra la sua attenzione sul rapporto tra materiale e dimensione plastica delle forme. Cubic Glass è una libreria girevole con base specchiata e struttura in cristallo: una vera e propria scultura domestica.

En A design idea that focuses on the relationship between material and size, with plastic shapes. Cubic Glass is a rotating bookcase with a mirrored base and crystal structure - a true domestic sculpture.

De Design, das sich ganz auf das Zusammenspiel zwischen Material und Wahrnehmung der plastischen Form konzentriert. Cubic Glass ist ein drehbares Bücherregal mit Spiegelsockel und Glaskorpus - eine Skulptur für den privaten Wohnraum.

Fr Une idée conceptuelle qui concentre son attention sur le rapport entre matériau et dimension plastique des formes. Cubic Glass est une bibliothèque pivotante dotée d'une base miroir et d'une structure en cristal, ce qui en fait une véritable sculpture domestique.



Cubic Glass Gino Carollo
Libreria. Bookcase. Bücherregal. Étagère.



Kadou

Cultura e tradizione orientali e know-how produttivo Made in Italy si incontrano in un oggetto essenziale, ma fortemente evocativo. Kadou è un elegante appendiabiti che richiama le forme di un vaso di fiori tradizionale giapponese: il suo nome significa appunto “l’arte dei fiori”.

En Oriental culture and tradition and Italian production meet in an essential but strongly evocative item. Kadou is an elegant coat stand that recalls the shapes of a traditional Japanese vase of flowers: its name in fact means “the art of flowers”.

Fr Culture et tradition orientales mêlées à un savoir-faire Made in Italy pour un objet essentiel mais fortement évocateur. Kadou est un porte-manteau élégant qui rappelle les formes d’un vase de fleurs japonais. Son nom d’ailleurs signifie « l’art des fleurs ».

De Orientalische Kultur und Tradition treffen hier auf technisches Know-how „made in Italy“. Das Ergebnis: schlichtes Design von zugleich starker suggestiver Wirkung. Der elegante Kleiderständer Kadou erinnert in seiner Form an traditionelle japanische Blumenvasen. Tatsächlich bedeutet sein Name „Blumenkunst“.



Kadou Ryosuke Fukusada
Appendiabiti. Coat stand. Kleiderständer. Porte-manteaux.





Kadou Ryosuke Fukusada
Appendiabiti. Coat stand. Kleiderständer. Porte-manteaux.

Kadou Light

Kadou è disponibile anche nella versione con luce: un'interpretazione originale dell'essenzialità formale della tradizione orientale, un incontro tra culture. Kadou Light, con la sua base illuminata, svolge la doppia funzione di appendiabiti e lampada.

En Kadou is also available in the version with a light - an original interpretation with the formal elemental appeal of oriental tradition, a meeting of cultures. Kadou Light, with its illuminated base, has a dual role as a coat stand and a lamp.

De Kadou ist auch in der Ausführung mit Beleuchtung erhältlich. Eine originelle Interpretation der formalen Schlichtheit orientalischer Tradition, eine Begegnung der Kulturen. Kadou Light fungiert mit seiner beleuchteten Basis gleichermaßen als Kleiderständer wie als Leuchte.

Fr Kadou existe également dans la version avec éclairage : une interprétation originale de la sobriété des formes dans la tradition orientale, une rencontre entre les cultures. Avec sa base éclairée, Kadou Light revêt une double fonction : porte-manteau et lampe.

Kadou Light Ryosuke Fukusada
Appendiabiti e lampada. Coat stand and lamp.
Kleiderständer und Leuchte. Porte-manteau et lampe.



Tree

Un oggetto unico, di forte riconoscibilità e di grande valenza espressiva. Tree è un appendiabiti che conferisce personalità al paesaggio domestico. Grazie alla resistenza agli agenti atmosferici, può essere collocato anche all'esterno.

En A unique item, strongly distinctive and with great expressive value. Tree is a coat stand that gives personality to the domestic landscape. It is resistant to atmospheric agents and can also be used outdoors.

De Einzigartig, mit hohem Wiedererkennungswert und ausdrucksstarkem Design. Der Kleiderständer Tree verleiht Wohnräumen zweifellos Charakter. Dank seiner Witterungsbeständigkeit lässt sich Tree aber auch problemlos im Freien aufstellen.

Fr Un objet unique, au langage immédiat et d'une grande valeur expressive. Tree est un porte-manteau qui vient personnaliser le paysage domestique. Grâce à sa résistance aux agents atmosphériques, il peut également être installé à l'extérieur.

Tree Mario Mazzer
Appendiabiti. Coat stand. Kleiderständer. Porte-manteaux.





Tree Mario Mazzer
Appendiabiti. Coat stand. Kleiderständer. Porte-manteaux.

Tree Light

L'intensità espressiva e l'identità formale interpretate in una chiave particolare: Tree Light è la versione lampada di Tree, realizzata nel solo colore bianco: purezza, essenzialità, modernità.

En Expressive intensity and formal identity with an unusual interpretation: Tree Light is the lamp version of Tree, only made in white: purity, elemental appeal and modernity.

De Ausdruckskraft und Formensprache von Tree neu interpretiert. In der Ausführung Tree Light wird das Modell kurzerhand zur Leuchte. Erhältlich ausschließlich in reinem, schlichtem, modernem Weiß.

Fr L'intensité expressive et l'identité des formes se déclinent ici dans une version particulière avec éclairage, disponible uniquement en blanc : Tree Light, pureté, sobriété, modernité.

Tree Light Mario Mazzer
Appendiabiti e lampada. Coat stand and lamp.
Kleiderständer und Leuchte. Porte-manteau et lampe.



Eos Eos Light



Eos, la dea dell'aurora nella mitologia greca: una figura con sembianze di fiore. Una forma originale ed evocativa ripresa da Eos, un appendiabiti che grazie all'eccezionale resistenza agli agenti atmosferici, può essere usato anche outdoor. È disponibile anche nella versione con luce, Eos Light.

En Eos, the goddess of dawn in Greek mythology: a figure who can appear as a flower. An original and evocative shape inspired by Eos, a coat stand whose exceptional resistance to atmospheric agents makes it suitable for outdoor use. It is also available in the version fitted with a light, Eos Light.

De Eos, die griechische Göttin der Morgenröte, verzaubert mit ihrer Gestalt einer Blume. Dieselbe originelle und suggestive Form greift auch der gleichnamige Kleiderständer auf. Dank seiner Witterungsbeständigkeit kann Eos zudem auch im Freien genutzt werden. Erhältlich auch in der Ausführung mit Beleuchtung, Eos Light.

Fr Éos, la déesse de l'aurore dans la mythologie grecque, une silhouette à l'apparence d'une fleur. Une forme originale et évocatrice inspirée d'Éos pour un porte-manteau dont la résistance exceptionnelle aux agents atmosphériques lui permet d'être utilisé aussi en extérieur. Il existe également une version avec éclairage: Eos Light.

Eos / Eos Light Mario Mazzer
Appendiabiti e lampada. Coat stand and lamp.
Kleiderständer und Leuchte. Porte-manteau et lampe.



Muffin Lamp

Una lampada ispirata alla semplice geometria degli stampi dei muffin, il famoso dolce americano. Il paralume è caratterizzato da un effetto drappeggio, che genera un interessante gioco di ombre, conferendo maggiore profondità alla luce.

En A lamp inspired by the simple geometry of muffin cases. The lampshade features a beguiling drapery effect that generates a fascinating game of shadows, giving the light more depth.

De Als Inspiration für die Leuchte Muffin dienten die charakteristischen Backförmchen des berühmten gleichnamigen amerikanischen Süßgebäcks. Das Design des Lampenschirms erinnert an kunstvoll drapierten Stoff und erzeugt spannende Schattenspiele, die dem Licht mehr Tiefe verleihen. -

Fr Une lampe inspirée de la géométrie simple des caissettes pour muffins, le célèbre gâteau américain. L'abat-jour est caractérisé par un effet drapé qui génère un jeu d'ombres intéressant et qui apporte une plus grande profondeur à la lumière.

Muffin Lamp Ryosuke Fukusada
Lampada. Lamp. Leuchte. Lampe.



XXLight

Un oggetto connotato da una grande forza scenografica, e non solo per l'importanza delle sue dimensioni. XXLight è una lampada che, grazie alla fonte luminosa posta all'interno, illumina l'ambiente circostante diffondendo la luce delicatamente verso l'alto.

En An item with connotations of great scenographic strength, not only due to its significant size. XXLight is a lamp that lights its surroundings and diffuses light delicately upwards due to the light source fitted inside.

De In jedem Fall eindrucksvoll, und das nicht nur wegen ihrer imposanten Größe. Die Leuchte XXLight erhellt die Umgebung dank entsprechender Lichtquelle in ihrem Inneren sanft mit nach oben gerichtetem Licht.

Fr Un objet au très grand impact visuel et pas uniquement du fait de sa taille imposante. XXLight est une lampe qui, grâce à la source lumineuse située à l'intérieur, éclaire l'espace environnant en diffusant une lumière délicate vers le haut.

XXLight D'Urbino e Lomazzi
Lampada. Lamp. Leuchte. Lampe.



New Perspective Mirror

Un oggetto dinamico e ricco di personalità, un elemento di arredo con una forte valenza decorativa. New Perspective Mirror è uno specchio che gioca con la profondità e la prospettiva, dando l'illusione di una stanza oltre lo specchio e lasciando spazio all'immaginazione di chi vi si trova davanti. Le linee sono disegnate a mano libera direttamente sulla superficie riflettente.

En A dynamic item rich in personality, a furnishing element with strong decorative value. New Perspective Mirror is a mirror that plays with depth and perspective, giving the illusion of a room beyond the mirror and leaving space for the imagination of the person standing before it. The lines are hand drawn freely straight onto the reflecting surface.

De Ein dynamisches und ausdrucksstarkes Wohnaccessoire von hohem dekorativem Wert. Der Spiegel New Perspective Mirror spielt mit der Tiefenwahrnehmung und Perspektive des Betrachters. Er schafft die Illusion eines Raums auf der anderen Seite des Spiegels und wirft so die Frage auf, wem wir da eigentlich gegenüber stehen. Die einzelnen Linien sind mit freier Hand direkt auf das Glas gezeichnet.

Fr Un objet dynamique et riche en personnalité, une pièce de mobilier à la forte valeur décorative. New Perspective Mirror joue avec la profondeur et la perspective. En donnant l'illusion d'une chambre de l'autre côté du miroir, il laisse libre cours à l'imagination de celui qui se trouve devant. Les lignes sont dessinées à main levée, directement sur la surface réfléchissante.



Red/Green/Blue



Black



Copper



New Perspective Mirror Alain Gilles
Specchio. Mirror. Spiegel. Miroir.

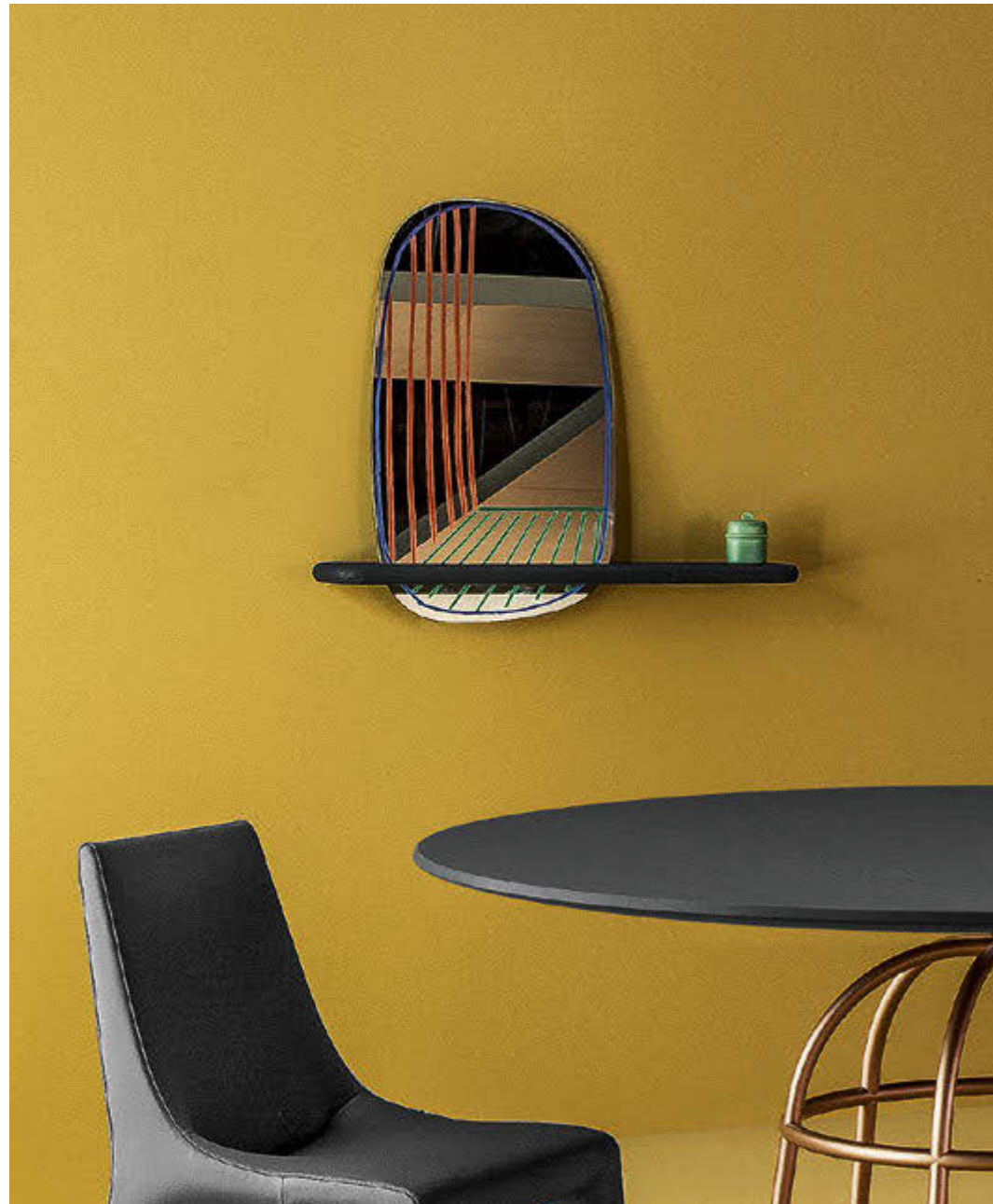

New Perspective Mirror Alain Gilles
Specchio. Mirror. Spiegel. Miroir.



Piers

In inglese si definiscono “piers” i capannoni nei porti, le cui forme geometriche richiamano quelle che compongono lo specchio Piers. Ogni figura elementare circoscrive una delle tre funzioni che il prodotto svolge: il quadrato diventa così un pratico appendiabiti, il cerchio uno specchio e il rettangolo un comodo piano d'appoggio. Utile e giocoso, Piers è in grado di assolvere a mansioni svolte solitamente da più complementi d'arredo.

En As its name suggests, Piers is made up of geometric shapes just like the raised structures on pillars found in ports. Each elementary figure circumscribes one of the three functions that the product performs. The square is a practical coat stand, the circle a mirror and the rectangle a convenient display surface. Useful and playful, Piers can fulfil tasks usually performed by a number of furnishing items.

De Im Englischen bezeichnet “piers” die Landungsstege im Hafen, an deren geometrische Formen das Design von Piers erinnert. Jede der drei Elementarformen erfüllt jeweils eine eigene Funktion. So wird das Quadrat zum praktischen Kleiderständer, der Kreis zum Spiegel und das Rechteck zur zweckmäßigen Ablage. Gleichermaßen nützlich wie verspielt übernimmt Piers damit eine Reihe von Aufgaben, für die gewöhnlich verschiedene Einrichtungsgegenstände benötigt werden.

Fr En anglais, ce terme désigne les quais aménagés dans les ports et dont les formes géométriques rappellent celles de Piers. Chaque figure élémentaire délimite une des trois fonctions revêtue par le produit : le carré devient ainsi un porte-manteau pratique, le cercle, un miroir; et le rectangle, une étagère. Utile et sympathique, Piers cumule plusieurs fonctions généralement remplies par plusieurs compléments de mobilier.



comb. 1



comb. 2



comb. 3



comb. 4

Piers Roberto Paoli
Specchio. Mirror. Spiegel. Miroir.



AX Mirror

I due elementi della X, vengono separati, a segnare simmetricamente l'oggetto e lo spazio. AX Mirror è uno specchio da abbinare alla omonima consolle o da scegliere da solo: per dare personalità all'ambiente domestico.

En The two elements of the X are separated, symmetrically marking the object and the space. AX Mirror is a mirror to be combined with the AX console or to be chosen alone, for giving personality to the domestic environment.

De Die beiden Diagonalen des X werden hier voneinander getrennt und symmetrisch angeordnet, um Gegenstand und Raum klar zu definieren. Egal ob in Kombination mit der gleichnamigen Konsole oder für sich allein verleiht AX Wohnräumen in jedem Fall einen besonderen Charakter.

Fr Les deux tiges du X se séparent pour marquer la symétrie dans l'objet et dans l'espace. Seul ou en association avec la console du même nom, AX Mirror apporte une touche de personnalité à l'espace domestique.



AX Mirror Gino Carollo
Specchio. Mirror. Spiegel. Miroir.
AX Console Gino Carollo
Consolle. Console. Konsole. Console.



Amond Mirror

Con un profilo che ricorda la silhouette di un diamante, Amond Mirror è uno specchio da abbinare alla omonima consolle o da scegliere da solo: una personalità spiccata, giocata nell'equilibrio tra i diversi materiali impiegati e un disegno di indubbia originalità.

En With a profile that looks like the silhouette of a diamond, Amond Mirror is a mirror to be combined with the Amond console or to be chosen alone. It has a distinctive personality, playing on the balance between the different materials used and an undoubtedly original design.

De Mit seinem Profil, das an die Silhouette eines Diamanten erinnert, passt Amond Mirror elegant zur gleichnamigen Konsole, überzeugt aber auch allein. Sein ausdrucksstarkes Design verdankt der Spiegel der gelungenen Kombination verschiedener Materialien und seiner zweifellos originellen Gestalt.

Fr Avec son profil qui rappelle la forme d'un diamant, Amond Mirror est un miroir que l'on peut utiliser seul ou en association avec la console du même nom, avec la certitude d'apporter une touche de personnalité, jouée sur l'équilibre des différents matériaux employés et un design incontestablement original.



Amond Mirror Gino Carollo
Specchio. Mirror. Spiegel. Miroir.
Amond Console Gino Carollo
Consolle. Console. Konsole. Console.

Spiral Mirror

Uno specchio ispirato alla cucitura a spirale che connota generalmente i bordi di oggetti in tessuto, pelle o feltro. Spiral Mirror è uno specchio caratterizzato da un cordoncino perimetrale in tessuto colorato che protegge e decora il bordo.

En A mirror inspired by the seam stitch which generally connotes the edge of fabric, leather or felt objects. Spiral Mirror is featuring a string edging made of coloured fabric that protects and decorates the border of the mirror.

De Als Inspiration für Spiral Mirror diente die spiralförmige Naht, die gewöhnlich die Ränder von Accessoires aus Stoff, Leder oder Filz ziert. Der Spiegel überrascht daher ebenfalls mit einer dekorativen Umrandung aus bunter Stoffschnur, die zugleich als Kantenschutz dient.

Fr Un miroir inspiré du point de surjet en couture, utilisé généralement pour surfiler les bords d'objets en tissu, cuir souple ou feutrine. Spiral Mirror est caractérisé par une cordelette en tissu coloré qui protège et orne le bord du miroir.



Spiral Mirror Ryosuke Fukusada
Specchio. Mirror. Spiegel. Miroir.



Hang up

Un tocco di movimento, un insolito gioco prospettico evidenziato dal contrasto di linee. Hang up si distingue per la posizione irregolare dello specchio rispetto alla cornice: la forma dello specchio lo fa sembrare svincolato dalla cornice stessa. La struttura retrostante è costituita da un telaio di acciaio verniciato, mentre la cornice è in legno.

En A touch of movement, an unusual play on perspective highlighted by contrasting lines. Hang up stands out due to the irregular position of the mirror in relation to the frame. The shape of the mirror makes it seem like it has been released from the frame. The background structure comprises a painted steel frame, whereas the frame is made of wood.

De Dynamische Linien, unerwartete Perspektiven, schiefe Konturen. Das Besondere an Hang up liegt in der asymmetrischen Anbringung von Spiegel und Rahmen. Der Spiegel scheint so vom Rahmen befreit. Das tragende Gestell dahinter besteht aus einem lackierten Stahlrahmen, der äußere Rahmen ist aus Holz gefertigt.

Fr Un peu de mouvement et voilà : un jeu de perspective insolite, souligné par le contraste des lignes. Hang up se distingue par la position irrégulière du miroir par rapport au cadre, comme si le miroir s'en était détaché. À l'arrière, la structure portante est constituée d'un châssis en acier verni tandis que le cadre est en bois.

Hang up Andrea Lucatello
Specchio. Mirror. Spiegel. Miroir.



Obel

Obel è uno specchio da parete che, grazie all'ampio spazio di riflessione, rende l'individuo protagonista assoluto. Leggermente inclinato e dalla forma trapezoidale, lo specchio poggia su una sottile struttura in legno a sua volta appoggiata alla parete, che gli conferisce volume e ricchezza.

En Obel is a wall mirror which affords a large reflective surface to make the individual play the starring role. Slightly tilted and shaped like a trapezium, the mirror rests on a slim wooden frame, which in turn rests against the wall, giving it volume and depth.

De Obel ist ein Wandspiegel, der dank seiner großzügigen Spiegeloberfläche den Betrachter klar in den szenischen Mittelpunkt rückt. Der leicht geneigte, trapezförmige Spiegel ruht auf einer dünnen Holzkonstruktion, die ihrerseits an der Wand montiert wird und dem Gesamtobjekt Volumen und Tiefe verleiht.

Fr Obel est un miroir mural qui fait de l'individu le protagoniste absolu grâce son ample espace de réflexion. Légèrement incliné et à la forme trapézoïdale, le miroir repose sur une fine structure en bois, appuyée à son tour contre le mur, qui lui confère volume et richesse.

Obel Roberto Paoli
Specchio. Mirror. Spiegel. Miroir.



Azero

Un tocco di movimento e di irriverente modernità. Azero è un originale specchio dalle linee dinamiche e moderne composto da elementi dalla forma trapezoidale. Posizionabili uno di fianco all'altro, singolarmente o in composizione libera.

En A touch of movement and disrespectful modernity. Azero is an original mirror featuring dynamic and modern silhouettes consisting of trapezoidal-shaped elements. They can be positioned side-by-side, individually, or freely in a composition.

De Dynamisch und respektlos modern. Das originelle Spiegel-Set Azero besteht aus zwei trapezförmigen Elementen, die mit einer lebendigen und modernen Linienführung bestechen. Die beiden Elemente können nebeneinander, einzeln oder frei nach Belieben angeordnet werden.

Fr Du mouvement et une évidente modernité de design. Azero est un original miroir aux lignes dynamiques et modernes, composé d'éléments de forme trapézoïdale. Positionnables l'un à côté de l'autre, ils peuvent s'utiliser seuls ou en composition libre.



Eclipse

Lo specchio come elemento magico per guardare con una nuova prospettiva gli oggetti e i luoghi della nostra quotidianità. Eclipse è uno specchio disponibile in tre diametri. Può essere utilizzato singolarmente oppure in set: gli specchi possono essere sovrapposti creando originali composizioni.

En The mirror as a magical element for looking at the items and places of everyday life from a new perspective. Eclipse is a mirror available in three diameters. It can be used stand-alone or in a set: the mirrors can be overlapped to create original compositions.

De Der Spiegel als magisches Element, das eine neue Perspektive auf die Gegenstände und Orte unseres Alltags ermöglicht. Eclipse ist in drei Größen erhältlich und kann einzeln oder als Set eingesetzt werden. Durch überlappende Anordnung der einzelnen Spiegel lassen sich originelle Zusammenstellungen kreieren.

Fr Le miroir comme élément magique pour regarder les objets et les lieux de notre vie quotidienne depuis une nouvelle perspective. Eclipse est un miroir disponible en trois diamètres. Il peut être utilisé seul ou en composition, les miroirs pouvant se superposer et s'agencer de manière originale.



Eclipse Gino Carollo
Specchio. Mirror. Spiegel. Miroir.



Hollywood

Un nuovo linguaggio degli oggetti, con forme che danno un'interpretazione originale all'esigenza di comodità. Hollywood è un pouf completamente sfoderabile, disponibile in due formati: Hollywood medium e Hollywood large.

En A new language for objects, featuring shapes that provide an original solution to the need for comfort. Hollywood is a pouf with a completely removable cover, available in two formats: Hollywood medium and Hollywood large.

De Eine neue Formensprache für originelle Sitzlösungen, die vor allem eines sind: unerhört bequem. Der vollständig abziehbare Pouf Hollywood ist in zwei Größen erhältlich, Hollywood medium und Hollywood large.

Fr Un nouveau langage pour les objets, avec des formes qui interprètent le besoin de confort avec originalité. Hollywood est un pouf entièrement déhoussable, disponible en deux formats : Hollywood medium et Hollywood large.

Hollywood Gino Carollo
Pouf





LT14

LT11

LT15

LT12

LT16

LT13

LT10

Hollywood Limited Edition Gino Carollo
Pouf

Cube

Un elemento d'arredo dalle linee originali, adatto a tutti gli ambiti della casa. Cube è un pouf disponibile in due dimensioni: Cube small e Cube big. I Cube possono essere usati singolarmente oppure abbinati tra loro.

En An interior décor item featuring original silhouettes, suitable for any room in the home. Cube is a pouf available in two sizes: Cube small and Cube big. The Cubes can be used individually or combined with each other.

De Ein Wohnaccessoire mit zweifellos origineller Linienführung, das sich perfekt für alle Bereiche in Haus und Wohnung eignet. Der Pouf Cube ist in zwei Größen erhältlich, Cube small und Cube big. Die beiden Varianten können einzeln oder zusammen verwendet werden.

Fr Une pièce de mobilier aux lignes originales, adaptée à toutes les pièces de la maison. Cube est un pouf disponible en deux formats : Cube small et Cube big. Les Cube peuvent s'utiliser seuls ou s'agencer les uns avec les autres.



Panorama

Un progetto dedicato ai modelli di vita contemporanei, in cui la tecnologia svolge un ruolo decisamente rilevante. Panorama è un portatelevisore con base girevole, caratterizzato dalla forma rettangolare e da vani laterali porta DVD. È disponibile anche nella versione con luce (Panorama Light).

En A project dedicated to contemporary lifestyles, where technology plays a decidedly significant role. Panorama is a TV unit with a revolving base, distinguished by a rectangular shape and lateral DVD storage compartments. It is also available in the version fitted with a light, Panorama Light.

De Design, das unserem modernen Lebensstil gerecht wird, indem es die Bedeutung moderner Technologien berücksichtigt. Panorama ist ein drehbares TV-Möbel mit rechteckigem Gestell und seitlichen Fächern zur Aufbewahrung von DVDs. Erhältlich auch in der Ausführung mit Beleuchtung (Panorama Light).

Fr Un concept dédié aux modèles de vie contemporains, où la technologie occupe une place importante. Panorama est un meuble TV avec base pivotante. De forme rectangulaire, il est caractérisé par des compartiments latéraux pour le rangement des DVD. Il existe également une version avec éclairage (Panorama Light).

Panorama Gino Carollo
Porta TV, TV unit, TV Möbel, Meuble-télévision.



Vision

Un progetto dedicato ai nostri strumenti tecnologici, sempre più numerosi, sempre più sofisticati. Vision è un portatelevisore con base girevole, caratterizzato dalla forma tonda e da vani laterali porta DVD.

En A design dedicated to our technological tools, which are constantly increasing in number and becoming more sophisticated. Vision is a TV unit with a revolving base, distinguished by a round shape and lateral DVD storage compartments.

De Design, das der steigenden Zahl und zunehmenden Komplexität unserer technischen Geräte gerecht wird. Vision ist ein drehbares TV-Möbel mit rundem Gestell und seitlichen Fächern zur Aufbewahrung von DVDs.

Fr Un projet dédié aux outils technologiques et de plus en plus sophistiqués qui caractérisent de plus en plus notre vie. Vision est un meuble TV avec base pivotante. De forme ronde, il est caractérisé par des compartiments latéraux pour le rangement des DVD.

Vision Gino Carollo
Porta TV. TV unit. TV Möbel. Meuble-télévision.



Informazioni tecniche. Technical information.
Technische Hinweise. Informations techniques.

Amond Console	P. 196	New Perspective Mirror	P. 224
Amond Mirror	P. 222	Note	P. 217
April, May, June	P. 216	Note Sideboard	P. 200
Arvo	P. 203	Obel	P. 225
AX Console	P. 197	Orion	P. 210
AX Mirror	P. 222	Panorama	P. 229
Azero	P. 223	Pebble	P. 210
Bend	P. 203	Pebble Pouf	P. 228
Collage	P. 204	Piers	P. 225
Coseno	P. 198	Planet, Planet Light	P. 211
Cosmos	P. 204	Ribbon	P. 212
Cube	P. 227	Spiral Mirror	P. 226
Cubic, Cubic Glass	P. 216	Spring	P. 200
Doppler	P. 205	Summer	P. 201
Doppler Sideboard	P. 199	Sunrise, Sunrise Light	P. 201
Duffy	P. 205	Tectonic	P. 212
Eclipse	P. 223	Tie	P. 213
Eos, Eos Light	P. 219	Tratto	P. 202
Fard	P. 206	Tree, Tree Light	P. 220
Folio	P. 207	Up and Down	P. 218
Frame Sideboard	P. 199	Vanity, Fortuny, Harry	P. 214
Fun	P. 217	Vision	P. 229
Hang Up	P. 224	Voilà	P. 214
Hollywood	P. 227	XXLight	P. 221
Icosì	P. 207		
Kadou, Kadou Light	P. 219		
Kadou Coffee	P. 208		
Magazine Bag	P. 215		
Mille Coffee	P. 208		
Monforte	P. 209		
Muffin, Muffin Light	P. 209		
Muffin Lamp	P. 220		

Amond Console



①

Finitura BASE / BASE FINISH / BASIS AUSFÜHRUNG / FINITION BASE

VERNICIATO OPACO

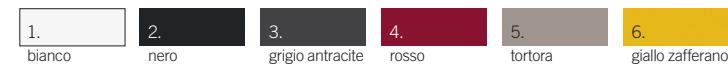

METALLO FINITURA



ACCIAIO

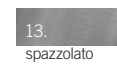

MAT PAINTED

- white
- black
- anthracite grey
- red
- dove grey
- saffron yellow
- green
- blue
- bordeaux

LACKIERT MATT

- Weiss
- Schwarz
- Anthrazitgrau
- Rot
- Taubengrau
- Saafengelb
- Grün
- Blau
- Bordeaux

VERNI OPAQUE

- blanc
- noir
- gris anthracite
- rouge
- gris tourterelle
- jaune safran
- vert
- bleu
- bordeaux

METAL FINISH

- copper
- brass
- pickled

METALL AUSFÜHRUNG

- Kupfer
- Messing
- Stahlgrau

FINITION MÉTAL

- cuivre
- laiton
- décapé

STEEL

- polished

STAHL

- poliert

ACIER

- brossé

DIMENSIONI / DIMENSIONS / GRÖßEN / DIMENSIONS

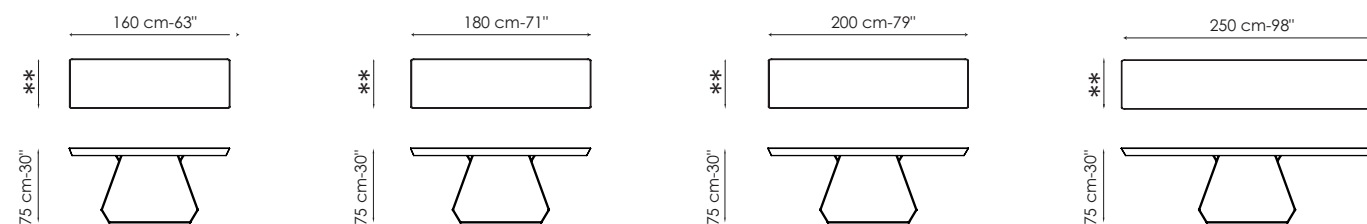

** 50 cm - 20"
legno / wood / Holz / bois
49 cm - 19.2"
ceramica / ceramic / Keramik / céramique

AX Console



①

FINITURA GAMBE / LEGS FINISH / BEINE AUSFÜHRUNG / FINITION PIEDS

VERNICIATO OPACO



METALLO FINITURA



MAT PAINTED

- white
- black
- anthracite grey
- red
- dove grey
- saffron yellow
- green
- blue
- bordeaux

LACKIERT MATT

- Weiss
- Schwarz
- Anthrazitgrau
- Rot
- Taubengrau
- Saafengelb
- Grün
- Blau
- Bordeaux

VERNI OPAQUE

- blanc
- noir
- gris anthracite
- rouge
- gris tourterelle
- jaune safran
- vert
- bleu
- bordeaux

METAL FINISH

- burnished

METALL AUSFÜHRUNG

- Brüniert

FINITION MÉTAL

- bruni

②

FINITURA PIANO / TOP FINISH / PLATTE AUSFÜHRUNG / FINITION PLAN

LEGNO MASSICCIO



CERAMICA LUCIDA

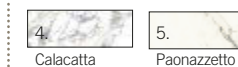

CERAMICA OPACA



SOLID WOOD

- American walnut*
- natural polished oak
- anthracite grey polished oak

MASSIVHOLZ

- Amerikaner Nussbaum*
- Eiche Natur poliert
- Eiche Anthrazitgrau poliert

BOIS MASSIF

- noyer américain*
- rouvre brossé naturel
- rouvre brossé gris anthracite

GLOSSY CERAMIC

- Calacatta
- Paonazzetto

GLÄNZEND KERAMIC

- Calacatta
- Paonazzetto

CÉRAMIQUE BRILLANT

- Calacatta
- Paonazzetto

MAT CERAMIC

- graphite grey
- iridium white

MATT KERAMIC

- Graphitgrau
- Iridium Weiss

CÉRAMIQUE OPAQUE

- gris graphite
- blanc iridium

DIMENSIONI / DIMENSIONS / GRÖßEN / DIMENSIONS

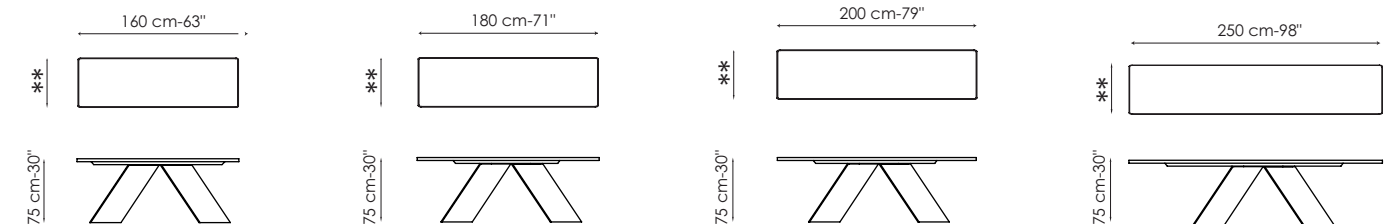

** 50 cm - 20"
legno / wood / Holz / bois
49 cm - 19.2"
ceramica / ceramic / Keramik / céramique

coseno



①

FINITURA GAMBE / LEGS FINISH / BEINE AUSFÜHRUNG / FINITION PIEDS

VERNICIATO OPACO



METALLO FINITURA

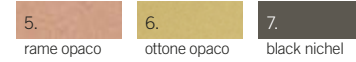

MAT PAINTED

- 1. black
- 2. anthracite grey
- 3. racing green
- 4. bordeaux

LACKIERT MATT

- 1. Schwarz
- 2. Anthrazitgrau
- 3. Racing green
- 4. Bordeaux

VERNI OPAQUE

- 1. noir
- 2. gris anthracite
- 3. racing green
- 4. bordeaux

METAL FINISH

- 5. mat copper
- 6. mat brass
- 7. black nickel

METALL AUSFÜHRUNG

- 5. Kupfer matt
- 6. Messing matt
- 7. Schwarz vernickelt

FINITION MÉTAL

- 5. cuivre opaque
- 6. laiton opaque
- 7. noir nickel

②

Finitura piano / TOP FINISH / PLATTE AUSFÜHRUNG / FINITION PLAN

LEGNO IMPIALLACCIATO



VENEREED WOOD

- 1. walnut canaletto
- 2. natural oak
- 3. anthracite grey oak

HOLZ FURNIERT

- 1. Nussbaum Canaletto
- 2. Eiche Natur
- 3. Eiche Anthrazitgrau

BOIS PLAQUÉ

- 1. noyer canaletto
- 2. rouvre naturel
- 3. rouvre gris anthracite

DIMENSIONI / DIMENSIONS / GRÖßEN / DIMENSIONS

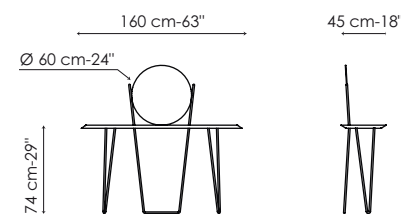

DOPPLER SIDEBOARD

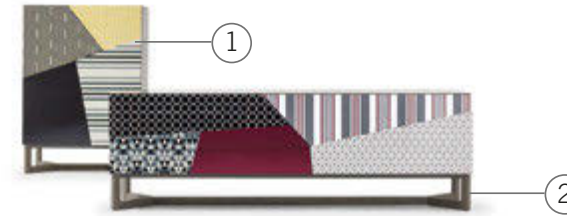

①

FINITURA STRUTTURA / FRAME FINISH / GESTELL AUSFÜHRUNG / FINITION STRUCTURE

ESTERNO LACCATO OPACO



OUTSIDE

- LACQUERED MAT**
1. black

AUBEN

- LACKIERT MATT**
1. Schwarz

EXTÉRIEUR

- LAQUÉ OPAQUE**
1. noir

②

FINITURA BASE / BASE FINISH / BASIS AUSFÜHRUNG / FINITION BASE

LEGNO MASSELLO



SOLID WOOD

- 1. walnut painted ash
- 2. natural ash
- 3. ash grey

MASSIVHOLZ

- 1. Eschen Nussbaumfarbig lackiert
- 2. Eschen Natur
- 3. Eschen Grau

BOIS MASSIF

- 1. frêne teinté noyer
- 2. frêne naturel
- 3. frêne gris

DIMENSIONI / DIMENSIONS / GRÖßEN / DIMENSIONS

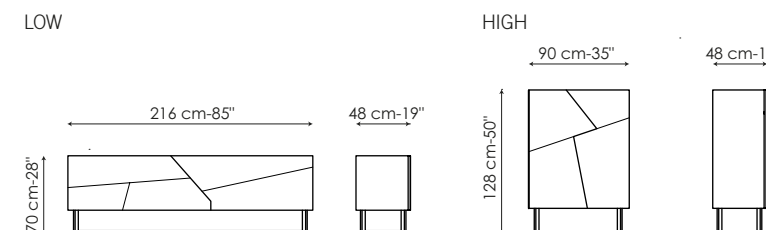

FRAME SIDEBOARD



①

FINITURA STRUTTURA / FRAME FINISH / GESTELL AUSFÜHRUNG / FINITION STRUCTURE

VERNICIATO OPACO

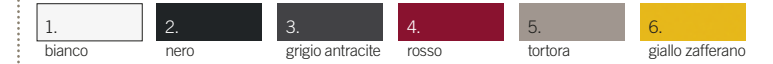

METALLO FINITURA



MAT PAINTED

- 1. white
- 2. black
- 3. anthracite grey
- 4. red
- 5. dove grey
- 6. saffron yellow
- 7. green
- 8. blue
- 9. bordeaux

LACKIERT MATT

- 1. Weiss
- 2. Schwarz
- 3. Anthrazitgrau
- 4. Rot
- 5. Taubengrau
- 6. Saafangelb
- 7. Grün
- 8. Blau
- 9. Bordeaux

VERNI OPAQUE

- 1. blanc
- 2. noir
- 3. gris anthracite
- 4. rouge
- 5. gris tourterelle
- 6. jaune safran
- 7. vert
- 8. bleu
- 9. bordeaux

METAL FINISH

- 10. mat copper
- 11. mat brass

METALL AUSFÜHRUNG

- 10. Kupfer matt
- 11. Messing matt

FINITION MÉTAL

- 10. cuivre opaque
- 11. laiton opaque

②

FINITURA ANTE, FIANCHI E TOP / DOORS, SIDES AND TOP FINISH / TÜREN, FLANKEN UND OBERE PLATTE / FINITION PORTES, CÔTÉS, PARTIE

LEGNO IMPIALLACCIATO



VENEREED WOOD

- 1. walnut canaletto
- 2. natural oak
- 3. anthracite grey oak
- 4. heat-treated oak

HOLZ FURNIERT

- 1. Nussbaum Canaletto
- 2. Eiche Natur
- 3. Eiche Anthrazitgrau
- 4. thermo-behandelte Eiche

BOIS PLAQUÉ

- 1. noyer canaletto
- 2. rouvre naturel
- 3. rouvre gris anthracite
- 4. rouvre traité thermiquement

DIMENSIONI / DIMENSIONS / GRÖßEN / DIMENSIONS

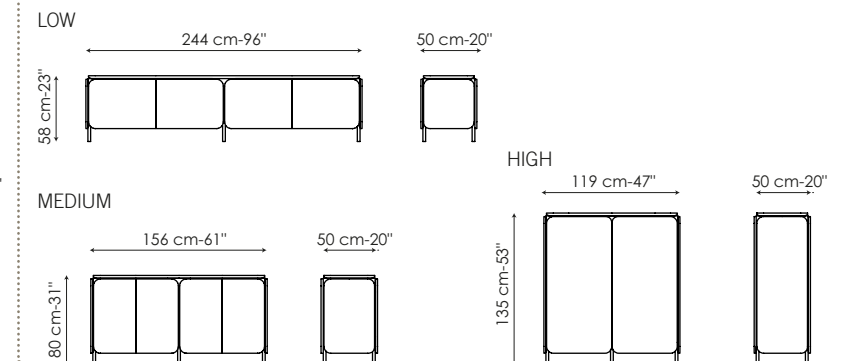

NOTE SIDEBOARD



①

FINITURA STRUTTURA (A) E ASSI (B) / FRAME (A) AND BEAMS (B) FINISH / GESTELL (A) UND STÜTZEN (B) AUSFÜHRUNG / FINITION STRUCTURE (A) ET AXES (B)



COMBINAZIONE 1
struttura: laccato opaco bianco (A)
assi: laccato opaco bianco (B)



COMBINAZIONE 2
struttura: noce canaletto (A)
assi: laccato opaco marrone (B)



COMBINAZIONE 3
struttura: rovere termotrattato (A)
assi: laccato opaco marrone (B)

- | | | |
|--|--|---|
| COMBINATION 1
frame: mat lacquered white (A)
beams: mat lacquered white (B) | KOMBINATION 1
Struktur: Weiss Lackiert matt (A)
Stützen: Weiss Lackiert matt (B) | COMBINAISON 1
structure: laqué blanc opaque (A)
axes: laqué blanc opaque (B) |
| COMBINATION 2
frame: canaletto walnut (A)
beams: mat lacquered brown (B) | KOMBINATION 2
Struktur: Nussbaum Canaletto (A)
Stützen: Braun Lackiert matt (B) | COMBINAISON 2
structure: noyer canaletto (A)
axes: laqué marron opaque (B) |
| COMBINATION 3
frame: heat-treated oak (A)
beams: mat lacquered brown (B) | KOMBINATION 3
Struktur: thermo-behandeltes Eiche (A)
Stützen: Braun Lackiert matt (B) | COMBINAISON 3
structure: rovere traité thermiquement (A)
axes: laqué marron opaque (B) |

DIMENSIONI / DIMENSIONS / GRÖßEN / DIMENSIONS

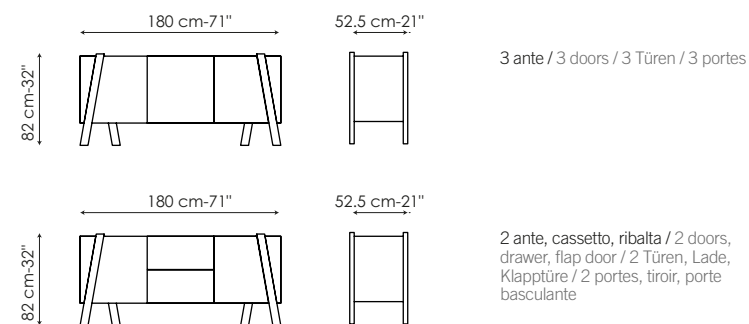

SPRING

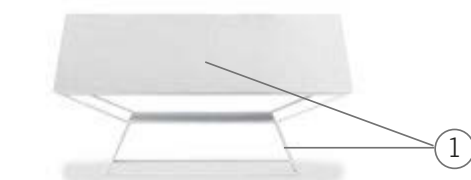

①

FINITURA STRUTTURA E BASE / FRAME AND BASE FINISH / GESTELL UND BASIS AUSFÜHRUNG / FINITION STRUCTURE ET BASE

LACCATO OPACO

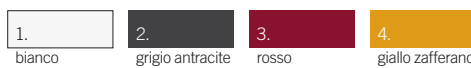

MAT LACQUERED

- white
- anthracite grey
- red
- saffron yellow

LACKIERT MATT

- Weiss
- Anthrazitgrau
- Rot
- Safrangelb

LAQUÉ OPAQUE

- blanc
- gris anthracite
- rouge
- jaune safran

DIMENSIONI / DIMENSIONS / GRÖßEN / DIMENSIONS

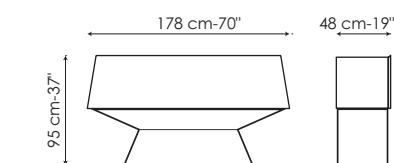

SUMMER



①

FINITURA STRUTTURA E BASE / FRAME AND BASE FINISH / GESTELL UND BASIS AUSFÜHRUNG / FINITION STRUCTURE ET BASE

LACCATO OPACO



MAT LACQUERED

- white
- anthracite grey
- red
- saffron yellow

LACKIERT MATT

- Weiss
- Anthrazitgrau
- Rot
- Safrangelb

LAQUÉ OPAQUE

- blanc
- gris anthracite
- rouge
- jaune safran

DIMENSIONI / DIMENSIONS / GRÖßEN / DIMENSIONS

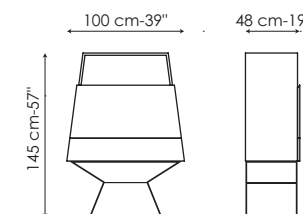

SUNRISE, SUNRISE LIGHT



①

FINITURA STRUTTURA / FRAME FINISH / GESTELL AUSFÜHRUNG / FINITION STRUCTURE

LACCATO OPACO



MAT PAINTED

- white
- anthracite grey
- quartz grey

LACKIERT MATT

- Weiss
- Anthrazitgrau
- Grau Quarz

VERNI OPAQUE

- blanc
- gris anthracite
- gris quartz

DIMENSIONI / DIMENSIONS / GRÖßEN / DIMENSIONS

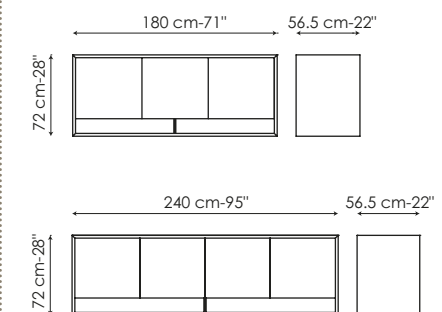

TRATTO



1

FINITURA ANTE E FIANCHI / DOORS AND SIDES FINISH / TÜREN UND FLANKEN AUSFÜHRUNG / FINITION PORTES ET CÔTÉS

LEGNO IMPIALLACCIATO

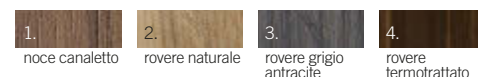

VENEREED WOOD

- walnut canaletto
- natural oak
- anthracite grey oak
- heat-treated oak

HOLZ FURNIERT

- Nussbaum Canaletto
- Eiche Natur
- Eiche Anthrazitgrau
- thermo-behandelte Eiche

BOIS PLAQUÉ

- noyer canaletto
- rouvre naturel
- rouvre gris anthracite
- rouvre traité thermiquement

2

FINITURA BASE E TOP / BASE AND TOP FINISH / BASIS UND OBERE PLATTE AUSFÜHRUNG / FINITION BASE ET PARTIE

VERNICIATO/LACCATO OPACO

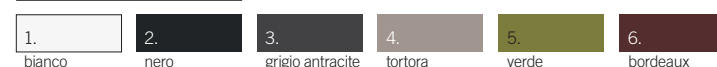

MAT PAINTED/LACQUERED

- white
- black
- anthracite grey
- dove grey
- green
- bordeaux

LACKIERT MATT

- Weiss
- Schwarz
- Anthrazitgrau
- Taubengrau
- Grün
- Bordeaux

VERNI/LAQUÉ OPAQUE

- bianc
- noir
- gris anthracite
- gris tourterelle
- vert
- bordeaux

DIMENSIONI / DIMENSIONS / GRÖßEN / DIMENSIONS

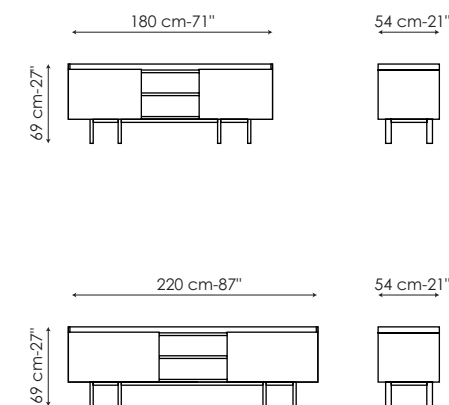

ARVO

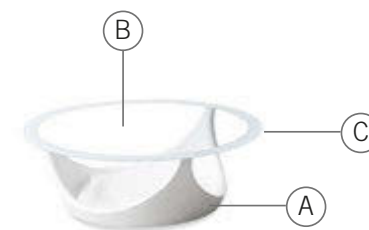

1

FINITURA BASE, PIANO, FASCIA / BASE, TOP, BAND FINISH / GESTELL, PLATTE, ZIERRAND AUSFÜHRUNG / FINITION BASE, PLATEAU ET BANDE PÉRIMÉTRALE

FINITURA

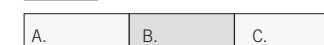

COMBINAZIONE 1

- A. base: polietilene bianco opaco
- B. piano: cristallo extrac. trasparente
- C. fascia perimetrale: bianco

COMBINAZIONE 2

- A. base: polietilene grigio antracite opaco
- B. piano: cristallo nero fumé
- C. fascia perimetrale: grigio antracite



COMBINAZIONE 3

- A. base: polietilene tortora opaco
- B. piano: cristallo nero fumé
- C. fascia perimetrale: grigio antracite



COMBINAZIONE 4

- A. base: polietilene bronzo opaco
- B. piano: cristallo nero fumé
- C. fascia perimetrale: grigio antracite

COMBINATION 1

- A. base: mat white polyethylene
- B. top: extra-light transparent
- C. perimeter band: white

KOMBINATION 1

- A. Gestell: Matt Weiss Polyethylen
- B. Platte: Klarglas extra-hell
- C. Zierrand: Weiss

COMBINAISON 1

- A. base: polyéthylène blanc opaque
- B. plateau: transparent extra-clair
- C. bande périmétrale: blanc

COMBINATION 2

- A. base: mat anthracite grey polyethylene
- B. top: smoked black glass
- C. perimeter band: anthracite grey

KOMBINATION 2

- A. Gestell: Matt Anthrazitgrau Polyethylen
- B. Platte: Rauchschwarz Glas
- C. Zierrand: Anthrazitgrau

COMBINAISON 2

- A. base: polyéthylène gris anthracite opaque
- B. plateau: cristal noir fumé
- C. bande périmétrale: gris anthracite

COMBINATION 3

- A. base: mat dove grey polyethylene
- B. top: smoked black glass
- C. perimeter band: anthracite grey

KOMBINATION 3

- A. Gestell: Matt Taubengrau Polyethylen
- B. Platte: Rauchschwarz Glas
- C. Zierrand: Anthrazitgrau

COMBINAISON 3

- A. base: polyéthylène gris tourterelle
- B. plateau: cristal noir fumé
- C. bande périmétrale: gris anthracite

COMBINATION 4

- A. base: mat bronze polyethylene
- B. top: smoked black glass
- C. perimeter band: anthracite grey

KOMBINATION 4

- A. Gestell: Matt Bronze Polyethylen
- B. Platte: Rauchschwarz Glas
- C. Zierrand: Anthrazitgrau

COMBINAISON 3

- A. base: polyéthylène bronze opaque
- B. plateau: cristal noir fumé
- C. bande périmétrale: gris anthracite

DIMENSIONI / DIMENSIONS / GRÖßEN / DIMENSIONS

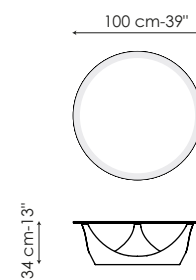

BEND



1

FINITURA STRUTTURA / FRAME FINISH / GESTELL AUSFÜHRUNG / FINITION STRUCTURE

VERNICIATO OPACO



7. verde

8. blu

9. giallo zafferano

10. arancio

11. bordeaux

12. coffee brown

13. racing green

14. azzurro artico

15. mattone

16. verde menta

MAT PAINTED

- white
- black
- anthracite grey
- red
- dove grey
- brown
- green
- blue
- safron yellow
- orange
- bordeaux
- coffee brown
- racing green
- arctic blue
- brick red
- mint green

LACKIERT MATT

- Weiss
- Schwarz
- Anthrazitgrau
- Rot
- Taubengrau
- Braun
- Grün
- Blau
- Safrangelb
- Orange
- Bordeaux
- Coffee Brown
- Racing Green
- Arktisch blau
- Ziegelrot
- Minzgrün

VERNI OPAQUE

- bianc
- noir
- gris anthracite
- rouge
- gris tourterelle
- marron
- vert
- bleu
- jaune safran
- orang
- bordeaux
- coffee brown
- racing green
- bleu artique
- brique
- vert menthe

2

Finitura piano / TOP FINISH / PLATTE AUSFÜHRUNG / FINITION PLAN

LEGNO MASSELLO



SOLID WOOD

- American walnut
- natural polished oak
- anthracite grey polished oak

MASSIVHOLZ

- Amerikaner Nussbaum
- Eiche Natur poliert
- Eiche anthrazitgrau poliert

BOIS MASSIF

- noyer américain
- rouvre brossé naturel
- rouvre brossé gris anthracite

DIMENSIONI / DIMENSIONS / GRÖßEN / DIMENSIONS

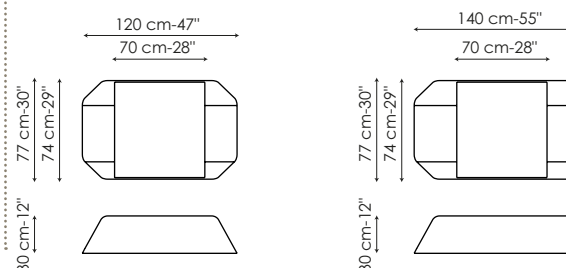

COLLAGE



1
FINITURA STRUTTURA / FRAME FINISH / GESTELL AUSFÜHRUNG / FINITION STRUCTURE

LACCATO OPACO



COMBINAZIONE 1
a) verniciato bianco opaco
b) verniciato bianco opaco
c) verniciato bianco opaco
d) verniciato bianco opaco
e) verniciato bianco opaco

COMBINAZIONE 2
a) verniciato amaranto opaco
b) verniciato arancio opaco
c) verniciato marrone opaco
d) verniciato tortora opaco
e) verniciato rosa cipria opaco



COMBINAZIONE 3
a) verniciato amaranto opaco
b) verniciato verde opaco
c) verniciato marrone opaco
d) verniciato tortora opaco
e) verniciato rosa cipria opaco



COMBINAZIONE 4
a) verniciato bianco opaco
b) verniciato arancio opaco
c) verniciato arancio opaco
d) verniciato bianco opaco
e) verniciato bianco opaco

COMBINATION 1

a) painted mat white
b) painted mat white
c) painted mat white
d) painted mat white
e) painted mat white

COMBINATION 2

a) painted mat amaranth
b) painted mat orange
c) painted mat brown
d) painted mat dove grey
e) painted mat powder pink

COMBINATION 3

a) painted mat amaranth
b) painted mat green
c) painted mat brown
d) painted mat dove grey
e) painted mat powder pink

COMBINATION 4

a) painted mat white
b) painted mat orange
c) painted mat orange
d) painted mat white
e) painted mat white

KOMBINATION 1

a) Lackiert Weiss matt
b) Lackiert Weiss matt
c) Lackiert Weiss matt
d) Lackiert Weiss matt
e) Lackiert Weiss matt

KOMBINATION 2

a) Lackiert Amaranth matt
b) Lackiert Orange matt
c) Lackiert Braun matt
d) Lackiert Taubengrau matt
e) Lackiert Puderrosa matt

KOMBINATION 3

a) Lackiert Amaranth matt
b) Lackiert Grün matt
c) Lackiert Braun matt
d) Lackiert Taubengrau matt
e) Lackiert Puderrosa matt

KOMBINATION 4

a) Lackiert Weiss matt
b) Lackiert Orange matt
c) Lackiert Orange matt
d) Lackiert Weiss matt
e) Lackiert Weiss matt

COMBINAISON 1

a) verni blanc opaque
b) verni blanc opaque
c) verni blanc opaque
d) verni blanc opaque
e) verni blanc opaque

COMBINAISON 2

a) verni amaranthe opaque
b) verni orange opaque
c) verni marron opaque
d) verni gris tourterelle opaque
e) verni rose poudre opaque

COMBINAISON 3

a) verni amaranthe opaque
b) verni vert opaque
c) verni marron opaque
d) verni gris tourterelle opaque
e) verni rose poudre opaque

COMBINAISON 4

a) verni blanc opaque
b) verni orange opaque
c) verni orange opaque
d) verni blanc opaque
e) verni blanc opaque

DIMENSIONI / DIMENSIONS / GRÖßEN / DIMENSIONS

ELEMENTI / ELEMENTS / ELEMENTE / ÉLÉMENTS

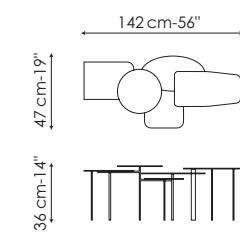
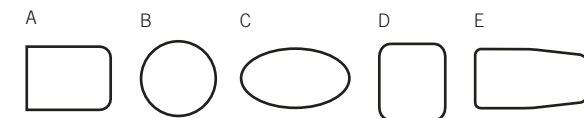

COSMOS, COSMOS LIGHT

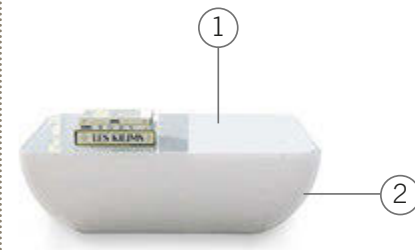

1
Finitura piano / TOP FINISH / PLATTE AUSFÜHRUNG / FINITION PLAN

COSMOS

CRISTALLO

1. extrachiaro vernic. bianco
2. extrachiaro vernic. nero

COSMOS LIGHT

CRISTALLO

3. extrachiaro vern. bianco con luce interna

GLASS

1. extra-light painted white
2. extra-light painted black
3. extra-light painted white with light inside

GLAS

1. extra-hell Weiss lackiert
2. extra-hell Schwarz lackiert
3. extra-hell Weiss lackiert mit Innenleuchte

CRISTAL

1. extra-clair verni blanc
2. extra-clair verni noir
3. extra-clair verni blanc avec lumière interne

2
FINITURA STRUTTURA / FRAME FINISH / GESTELL AUSFÜHRUNG / FINITION STRUCTURE

RIVESTIMENTO

pelle

UPHOLSTERY

leather

BEZUG

Leder

REVÊTEMENT

cuir souple

DIMENSIONI / DIMENSIONS / GRÖßEN / DIMENSIONS

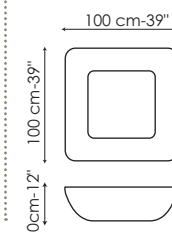

DOPPLER



1
FINITURA STRUTTURA / FRAME FINISH / GESTELL AUSFÜHRUNG / FINITION STRUCTURE

LEGNO MASSELLO

1. frassino tinto noce
2. frassino naturale
3. frassino tinto grigio

SOLID WOOD

1. walnut painted ash
2. natural ash
3. ash grey

MASSIVHOLZ

1. Eschen Nussbaumfarbig lackiert
2. Eschen Natur
3. Eschen Grau

BOIS MASSIF

1. frêne teinté noyer
2. frêne naturel
3. frêne gris

2
Finitura piano / TOP FINISH / PLATTE AUSFÜHRUNG / FINITION PLAN

1. HPL stampato (High Pressure Laminate)

1. printed HPL (High Pressure Laminate)

1. bedrucktem HPL (High Pressure Laminate)

1. HPL (High Pressure Laminate)

DIMENSIONI / DIMENSIONS / GRÖßEN / DIMENSIONS

DOPPLER HIGH

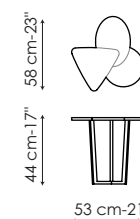

DOPPLER MIDDLE

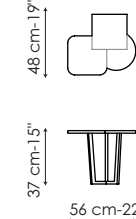

DOPPLER LOW

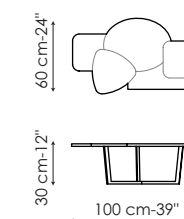

DUFFY



1
FINITURA STRUTTURA / FRAME FINISH / GESTELL AUSFÜHRUNG / FINITION STRUCTURE

POLIURETANO OPACO LACCATO

1. bianco
2. azzurro polvere
3. grigio chiaro
4. grigio antracite

MAT POLYURETHANE LACQUERED

1. white
2. powder blue
3. light grey
4. anthracite grey

POLYURETHAN MATT LACKIERT

1. Weiss
2. Pulverblau
3. Hellgrau
4. Anthrazitgrau

POLYURÉTHANE OPAQUE LAQUÉ

1. blanc
2. bleu-poudre
3. gris-clair
4. gris anthracite

DIMENSIONI / DIMENSIONS / GRÖßEN / DIMENSIONS

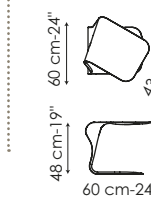

FARD

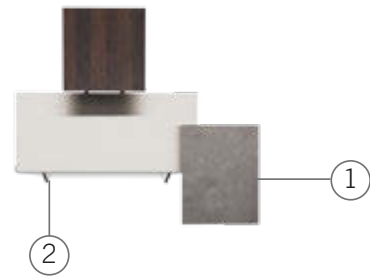

①

Finitura piano / TOP FINISH / PLATTE AUSFÜHRUNG / FINITION PLAN

LEGNO FINITURA BIOMALTA



LEGNO IMPIALLACCIATO



BIOMALTA FINISHED WOOD

- 1. light grey
- 2. dark grey

BIOMALTA AUSFÜHRUNG / HOLZ

- 1. hellgrau
- 2. dunkelgrau

BOIS FINITION BIOMALTA

- 1. gris clair
- 2. gris foncé

VENEREED WOOD

- 3. heat-treated oak

HOLZ FURNIERT

- 3. thermo-behandeltes Eiche

BOIS PLAQUÉ

- 3. rouvre traité thermiquement

②

FINITURA STRUTTURA / FRAME FINISH / GESTELL AUSFÜHRUNG / FINITION STRUCTURE

VERNICIATO OPACO



MAT PAINTED

- 1. white
- 2. anthracite grey
- 3. dove grey
- 4. black
- 5. amaranth

LACKIER MATT

- 1. Weiss
- 2. Anthrazitgrau
- 3. Taubengrau
- 4. Schwarz
- 5. Amaranth

VERNI OPAQUE

- 1. blanc
- 2. gris anthracite
- 3. gris tourterelle
- 4. noir
- 5. amarante

DIMENSIONI / DIMENSIONS / GRÖßEN / DIMENSIONS

FARD 1 FARD 2 FARD 3 FARD 4 FARD 5 FARD 6

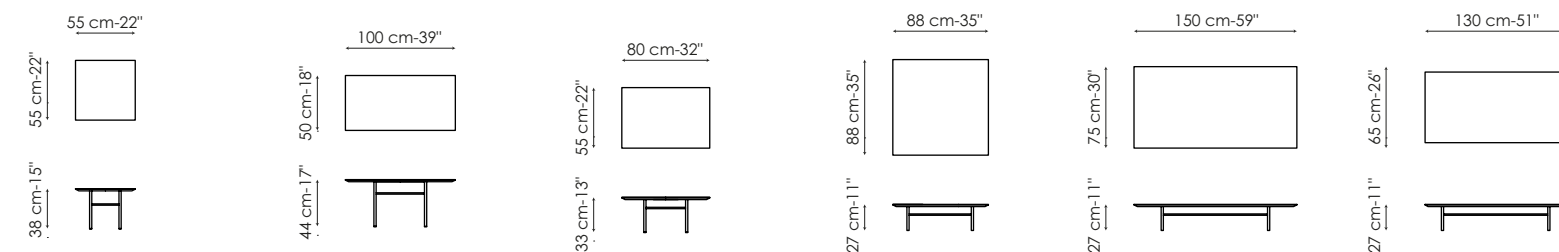

FOLIO



①

FINITURA STRUTTURA / FRAME FINISH / GESTELL AUSFÜHRUNG / FINITION STRUCTURE

CRISTALLO

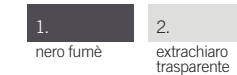

GLASS

- 1. smoked black
- 2. transparent extra-light

GLAS

- 1. Rauchschwarz
- 2. Klarglas extra-hell

CRISTAL

- 1. noir fumé
- 2. extra-clair transparent

②

FINITURA BASE / BASE FINISH / BASIS AUSFÜHRUNG / FINITION BASE

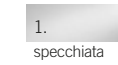

- 1. mirror finish

- 1. Verspiegelt

- 1. à miroir

DIMENSIONI / DIMENSIONS / GRÖßEN / DIMENSIONS

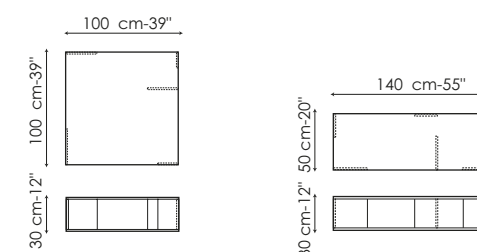

ICOSÌ



①

FINITURA STRUTTURA / FRAME FINISH / GESTELL AUSFÜHRUNG / FINITION STRUCTURE

VERNICIATO OPACO



METALLO FINITURA

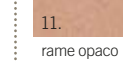

MAT PAINTED

- 1. white
- 2. anthracite grey
- 3. dove grey
- 4. powder pink
- 5. coral red
- 6. bordeaux
- 7. coffee brown
- 8. racing green
- 9. arctic blue
- 10. brick red

LACKIERT MATT

- 1. Weiss
- 2. Anthrazitgrau
- 3. Taubengrau
- 4. Puderrosa
- 5. Korallenrot
- 6. Bordeaux
- 7. Coffee Brown
- 8. Racing Green
- 9. Arktisch blau
- 10. Ziegelrot

VERNI OPAQUE

- 1. blanc
- 2. gris anthracite
- 3. gris tourterelle
- 4. rose poudré
- 5. rouge corail
- 6. bordeaux
- 7. coffee brown
- 8. racing green
- 9. bleu artique
- 10. brique

METAL FINISH

- 11. mat copper

METALL AUSFÜHRUNG

- 11. Kupfer matt

FINITION METAL

- 11. cuivre opaque

DIMENSIONI / DIMENSIONS / GRÖßEN / DIMENSIONS

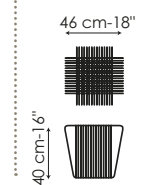

KADOU COFFEE



① **FINITURA RAMI / BRANCHES FINISH / ÄSTE AUSFÜHRUNG / FINITION BRAS**

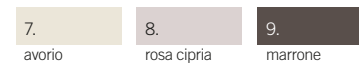
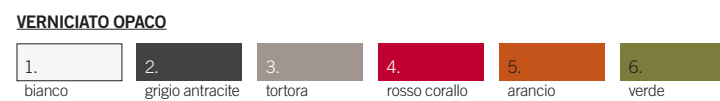

- | | | |
|--------------------|----------------------|---------------------|
| MAT PAINTED | LACKIERT MATT | VERNI OPAQUE |
| 1. white | 1. Weiss | 1. blanc |
| 2. anthracite grey | 2. Anthrazitgrau | 2. gris anthracite |
| 3. dove grey | 3. Taubengrau | 3. gris tourterelle |
| 4. coral red | 4. Korallenrot | 4. rouge corail |
| 5. orange | 5. Orange | 5. orange |
| 6. green | 6. Grün | 6. vert |
| 7. ivory | 7. Elfenbeinweiss | 7. ivoire |
| 8. powder pink | 8. Puderosa | 8. rose poudré |
| 9. brown | 9. Braun | 9. marron |

② **Finitura piano / TOP FINISH / PLATTE AUSFÜHRUNG / FINITION PLAN**



- | | | |
|--------------------|----------------------|---------------------|
| MAT PAINTED | LACKIERT MATT | VERNI OPAQUE |
| 1. white | 1. Weiss | 1. blanc |
| 2. anthracite grey | 2. Anthrazitgrau | 2. gris anthracite |
| 3. dove grey | 3. Taubengrau | 3. gris tourterelle |

DIMENSIONI / DIMENSIONS / GRÖßEN / DIMENSIONS

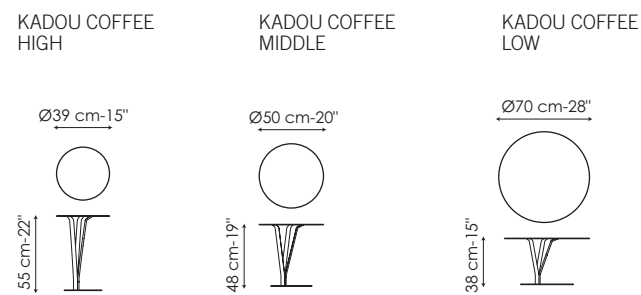

MILLE COFFEE



① **Finitura GAMBE / LEGS FINISH / BEINE AUSFÜHRUNG / FINITION PIEDS**



- | | | |
|---------------------|--------------------------|-----------------------|
| METAL FINISH | METALL AUSFÜHRUNG | FINITION MÉTAL |
| 1. chromed | 1. Verchromt | 1. chromé |

② **Finitura piano / TOP FINISH / PLATTE AUSFÜHRUNG / FINITION PLAN**



- | | | |
|----------------------|-------------|------------------------|
| GLASS | GLAS | CRISTAL |
| 1. transparent glass | 1. Klarglas | 1. cristal transparent |

DIMENSIONI / DIMENSIONS / GRÖßEN / DIMENSIONS

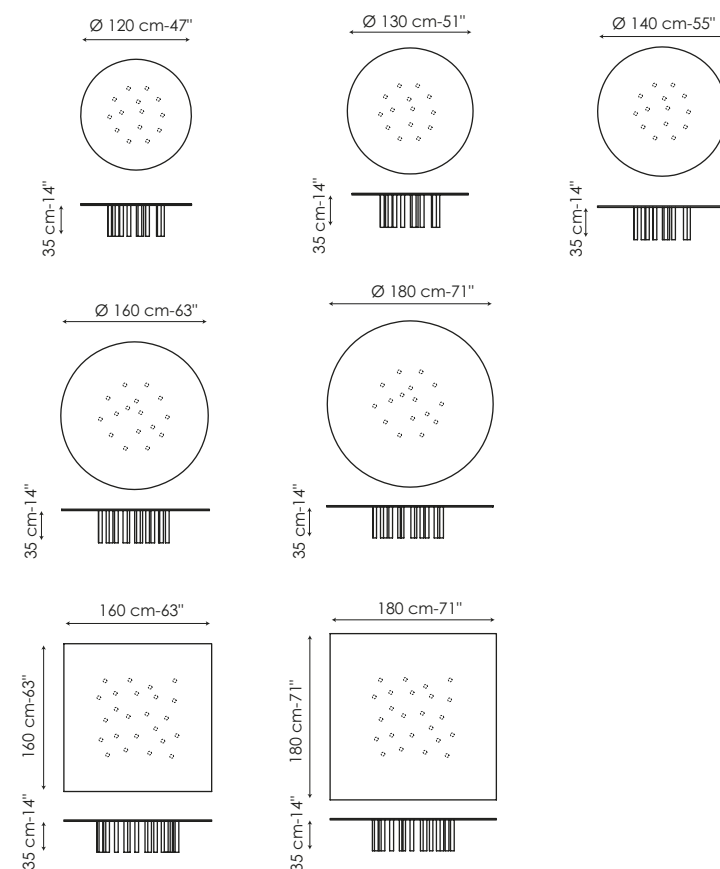

MONFORTE



① **Finitura GAMBE / LEGS FINISH / BEINE AUSFÜHRUNG / FINITION PIEDS**



- | | | |
|-----------------------------------|--|---------------------------------|
| SOLID WOOD | MASSIVHOLZ | BOIS MASSIF |
| 1. American walnut (not polished) | 1. Amerikaner Nussbaum (nicht poliert) | 1. noyer américain (pas brossé) |

② **Finitura piano / TOP FINISH / PLATTE AUSFÜHRUNG / FINITION PLAN**

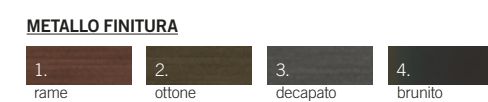

- | | |
|-------------------------------|------------------------|
| CRISTALLO | CERAMICA LUCIDA |
| 5. acidato nero | 7. Calacatta |
| 6. extrachiaro acidato bianco | 8. Paonazzetto |



- | | | |
|-----------------------------------|------------------------------|---------------------------------------|
| METAL FINISH | METALL AUSFÜHRUNG | FINITION MÉTAL |
| 1. copper | 1. Kupfer | 1. cuivre |
| 2. brass | 2. Messing | 2. laiton |
| 3. pickled | 3. Stahlgrau | 3. décapé |
| 4. burnished | 4. Brüniert | 4. bruni |
| GLASS | GLAS | CRISTAL |
| 5. acid-treated black | 5. Geätztes Schwarz | 5. traité à l'acide noir |
| 6. extra-light acid treated white | 6. Geätztes extra-hell Weiss | 6. extra-clair traité à l'acide blanc |
| GLOSSY CERAMIC | GLÄNZEND KERAMIC | CÉRAMIQUE BRILLANT |
| 7. Calacatta | 7. Calacatta | 7. Calacatta |
| 8. Paonazzetto | 8. Paonazzetto | 8. Paonazzetto |
| MAT CERAMIC | MATT KERAMIC | CÉRAMIQUE OPAQUE |
| 9. graphite grey | 9. Graphitgrau | 9. gris graphite |
| 10. iridium white | 10. Iridium Weiss | 10. blanc iridium |

DIMENSIONI / DIMENSIONS / GRÖßEN / DIMENSIONS

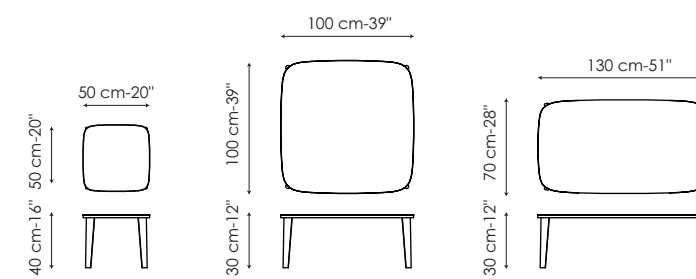

MUFFIN, MUFFIN LIGHT



① **FINITURA STRUTTURA / FRAME FINISH / GESTELL AUSFÜHRUNG / FINITION STRUCTURE**



- | | | |
|-------------------------|-------------------------|----------------------------|
| POLYETHYLENE MAT | POLYETHYLEN MATT | POLYÉTHYLÈNE OPAQUE |
| 1. white | 1. Weiss | 1. blanc |
| 2. anthracite grey | 2. Anthrazitgrau | 2. gris anthracite |
| 3. red | 3. Rot | 3. rouge |
| 4. dove grey | 4. Taubengrau | 4. gris tourterelle |
| 5. bronze | 5. Bronze | 5. bronze |

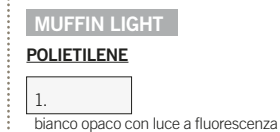

- | | | |
|---------------------------------|-------------------------------|------------------------------------|
| POLYETHYLENE MAT | POLYETHYLEN MATT | POLYÉTHYLÈNE OPAQUE |
| 1. white with fluorescent light | 1. Weiss mit Fluoreszenzlampe | 1. blanc avec lumière fluorescente |

② **Finitura piano / TOP FINISH / PLATTE AUSFÜHRUNG / FINITION PLAN (solo per / only for / nur / seulement Muffin)**

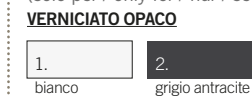

- | | | |
|--------------------|----------------------|---------------------|
| MAT PAINTED | LACKIERT MATT | VERNI OPAQUE |
| 1. white | 1. Weiss | 1. blanc |
| 2. anthracite grey | 2. Anthrazitgrau | 2. gris anthracite |

DIMENSIONI / DIMENSIONS / GRÖßEN / DIMENSIONS

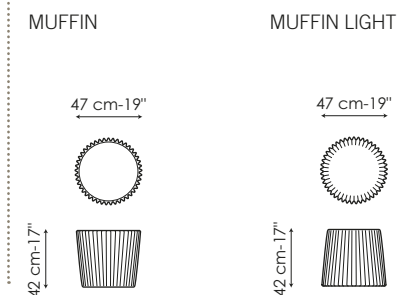

ORION



①

Finitura piano / TOP FINISH / PLATTE AUSFÜHRUNG / FINITION PLAN

CRISTALLO

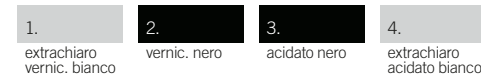

CERAMICA LUCIDA



CERAMICA OPACA
(solo Orion Ø50 cm, Ø97 cm)



GLASS

1. extra-light painted white
2. painted black
3. acid treated black
4. extra-light acid treated white

GLOSSY CERAMIC

5. Calacatta
6. Paonazzetto

MAT CERAMIC
(Orion Ø50 cm, Ø97 cm only)

7. graphite grey
8. iridium white

GLAS

1. Extra-hell Weiss lackiert
2. Schwarz lackiert
3. Geätztes Schwarz
4. Extra-hell Geätztes Weiss

GLÄNZEND KERAMIC

5. Calacatta
6. Paonazzetto

MATT KERAMIC
(nur Orion Ø50 cm, Ø97 cm)

7. Graphitgrau
8. Iridium Weiss

CRISTAL

1. extra-clair verni blanc
2. verni noir
3. traité à l'acide noir
4. extra-clair traité à l'acide blanc

CÉRAMIQUE BRILLANT

5. Calacatta
6. Paonazzetto

CÉRAMIQUE OPAQUE
(seulement pour Orion Ø50 cm, Ø97 cm)

7. gris graphite
8. blanc iridium

②

FINITURA STRUTTURA / FRAME FINISH / GESTELL AUSFÜHRUNG / FINITION STRUCTURE

VERNICIATO OPACO



PAINTED MAT

1. white
2. anthracite grey

LACKIERT MATT

1. Weiss
2. Anthrazitgrau

VERNI OPAQUE

1. blanc
2. gris anthracite

DIMENSIONI / DIMENSIONS / GRÖßEN / DIMENSIONS

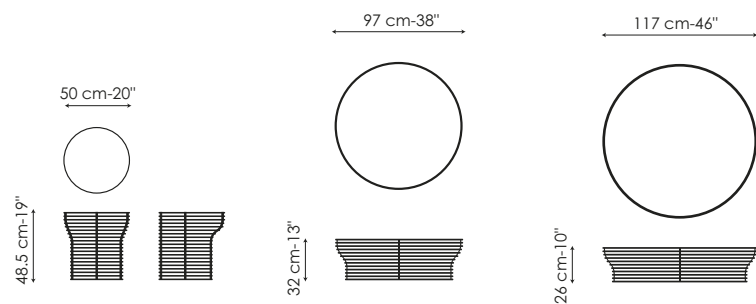

PEBBLE



①

FINITURA STRUTTURA / FRAME FINISH / GESTELL AUSFÜHRUNG / FINITION STRUCTURE

POLIETILENE OPACO

ESTERNO - INTERNO



MAT POLYETHYLENE

- OUTSIDE - INSIDE**
1. white - white
 2. white - grey
 3. white - powder blue
 4. red - white
 5. grey - white

POLYETHYLEN MATT

- AUSSEN - INNEN**
1. Weiss - Weiss
 2. Weiss - Grau
 3. Weiss - Pulverblau
 4. Rot - Weiss
 5. Grau - Weiss

POLYÉTHYLÈNE OPAQUE

- EXTÉRIEUR - INTÉRIEUR**
1. blanc - blanc
 2. blanc - gris
 3. blanc - bleu poudre
 4. rouge - blanc
 5. gris - blanc

DIMENSIONI / DIMENSIONS / GRÖßEN / DIMENSIONS

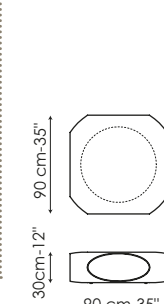

PLANET, PLANET LIGHT



PLANET, BIG PLANET

①

Finitura piano / TOP FINISH / PLATTE AUSFÜHRUNG / FINITION PLAN

CRISTALLO

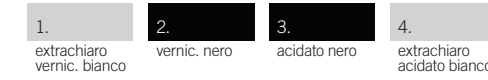

CERAMICA LUCIDA



CERAMICA OPACA
(solo Planet)



GLASS

1. extra-light painted white
2. painted black
3. acid treated black
4. extra-light acid treated white

GLOSSY CERAMIC

5. Calacatta
6. Paonazzetto

MAT CERAMIC
(Planet only)

7. graphite grey
8. iridium white

GLAS

1. Extra-hell Weiss lackiert
2. Schwarz lackiert
3. Geätztes Schwarz
4. Extra-hell Geätztes Weiss

GLÄNZEND KERAMIC

5. Calacatta
6. Paonazzetto

MATT KERAMIC
(nur Planet)

7. Graphitgrau
8. Iridium Weiss

CRISTAL

1. extra-clair verni blanc
2. verni noir
3. traité à l'acide noir
4. extra-clair traité à l'acide blanc

CÉRAMIQUE BRILLANT

5. Calacatta
6. Paonazzetto

CÉRAMIQUE OPAQUE
(seulement pour Planet)

7. gris graphite
8. blanc iridium

PLANET LIGHT, BIG PLANET LIGHT

①

Finitura piano / TOP FINISH / PLATTE AUSFÜHRUNG / FINITION PLAN

CRISTALLO EXTRACHIARO



EXTRA-LIGHT GLASS

1. painted white
2. acid treated white

GLAS EXTRA-HELL

1. Weiss lackiert
2. Geätztes Weiss

CRISTAL EXTRA-CLAIR

1. verni blanc
2. traité à l'acide blanc

②

FINITURA STRUTTURA / FRAME FINISH / GESTELL AUSFÜHRUNG / FINITION STRUCTURE

ALLUMINIO



ALUMINIUM

1. satin finish
2. painted glossy white
3. painted glossy black
4. painted mat anthracite grey
5. painted mat black

ALUMINIUM

1. Satiniert
2. Lackiert Weiss glänzend
3. Lackiert Schwarz glänzend
4. Lackiert Anthrazitgrau matt
5. Lackiert Schwarz matt

ALUMINIUM

1. satiné
2. verni blanc brillant
3. verni noir brillant
4. verni gris anthracite opaque
5. verni noir opaque

DIMENSIONI / DIMENSIONS / GRÖßEN / DIMENSIONS

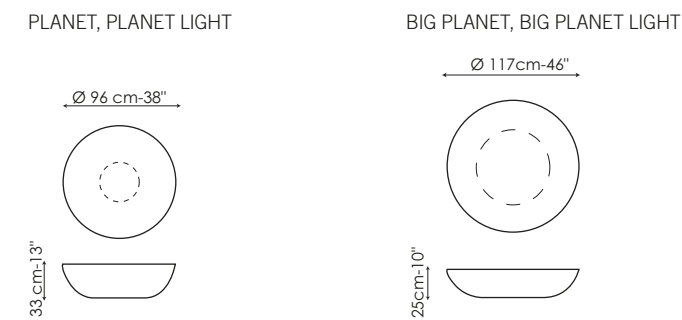

RIBBON



①

Finitura piano / TOP FINISH / PLATTE AUSFÜHRUNG / FINITION PLAN

MARMO OPACO

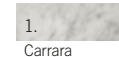

1. Carrara

MAT MARBLE

1. Carrara

MATT MARMOR

1. Carrara

MARBRE OPAQUE

1. Carrara

②

Finitura BASE / BASE FINISH / BASIS AUSFÜHRUNG / FINITION BASE

CRISTALLO



1. nero fumè

2. trasparente

GLASS

1. smoked black
2. transparent

GLAS

1. Rauchschwarz
2. Klarglas

CRISTAL

1. noir fumé
2. transparent

DIMENSIONI / DIMENSIONS / GRÖßEN / DIMENSIONS

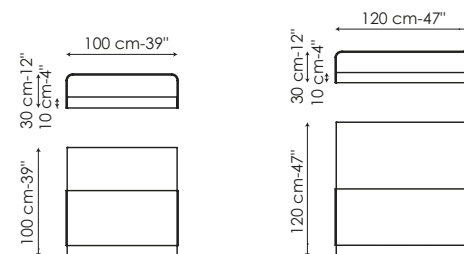

TECTONIC



①

Finitura STRUTTURA / FRAME FINISH / GESTELL AUSFÜHRUNG / FINITION STRUCTURE

VERNICIATO

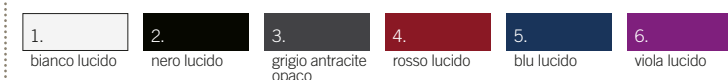

1. bianco lucido

2. nero lucido

3. grigio antracite opaco

4. rosso lucido

5. blu lucido

6. viola lucido

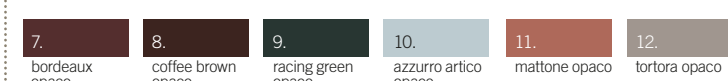

7. bordeaux opaco

8. coffee brown opaco

9. racing green opaco

10. azzurro artico opaco

11. mattone opaco

12. tortora opaco

METALLO FINITURA

(solo versione filo acciaio)

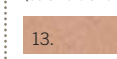

13. rame opaco

PAINTED

1. glossy white
2. glossy black
3. mat anthracite grey
4. glossy red
5. glossy blue
6. glossy violet
7. mat bordeaux
8. mat coffee brown
9. mat racing green
10. mat arctic blue
11. mat brick red
12. mat dove grey

LACKIERT

1. Weiss glänzend
2. Schwarz glänzend
3. Anthrazitgrau matt
4. Rot glänzend
5. Blau glänzend
6. Violett glänzend
7. bordeaux matt
8. coffee brown matt
9. racing green matt
10. arctic blue matt
11. brick red matt
12. Taubengrau matt

VERNI

1. blanc brillant
2. noir brillant
3. gris anthracite opaque
4. rouge brillant
5. bleu brillant
6. violet brillant
7. bordeaux opaque
8. coffee brown opaque
9. racing green opaque
10. bleu artique opaque
11. brique opaque
12. gris tourterelle opaque

METAL FINISH

(only steel wire)
13. mat copper

METALL AUSFÜHRUNG

(nur Drahtplatte)
13. Kupfer matt

FINITION METAL

(seulement fil en acier)
13. cuivre opaque

DIMENSIONI / DIMENSIONS / GRÖßEN / DIMENSIONS

* 35 cm - 14"
43 cm - 17"

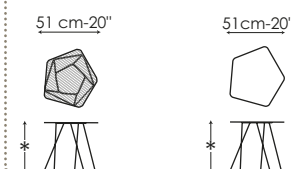

TIE

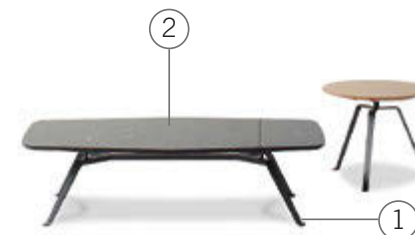

①

Finitura GAMBE / LEGS FINISH / BEINE AUSFÜHRUNG / FINITION PIEDS

VERNICIATO OPACO



1. bianco

2. grigio antracite

3. tortora

4. amaranto

METALLO FINITURA

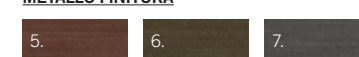

5. rame

6. ottone

7. decapato

②

Finitura piano / TOP FINISH / PLATTE AUSFÜHRUNG / FINITION PLAN

LACCATO LUCIDO

(solo Ø42 e Ø48)



1. caramello

2. blu pavone

3. kaki

4. marsala

5. blu cadetto

6. malva

LEGNO FINITURA BIOMALTA



7. grigio chiaro

8. grigio scuro

LEGNO IMPIALLACCIATO

(solo 120 cm e 150 cm)

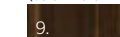

9. rovere spazzolato termotrattato

CERAMICA LUCIDA



10. Calacatta

11. Paonazzetto

CERAMICA OPAQA



12. grigio grafite

13. bianco iridium

MARMO LUCIDO O OPAKO

(solo 120 cm e 150 cm)



14. Calacatta

15. Carrara

16. Marquinia

17. Emperador

MAT PAINTED

1. white
2. anthracite grey
3. dove grey
4. amaranth

METAL FINISH

5. copper
6. brass
7. pickled

LACKIERT MATT

1. Weiss
2. Anthrazitgrau
3. Taubengrau
4. Amaranth

METALL AUSFÜHRUNG

5. Kupfer
6. Messing
7. Stahlgrau

VERNI OPAQUE

1. blanc
2. gris anthracite
3. gris tourterelle
4. amaranth

FINITION MÉTAL

5. cuivre
6. laiton
7. décapé

GLOSSY LACQUERED

(only Ø42 and Ø48)

1. caramel
2. peacock blue
3. khaki
4. marsala
5. cadet blue
6. mauve

GLÄNZEND LACKIERT

(nur Ø42 and Ø48)

1. Karamell
2. Pfauenblau
3. Khaki
4. Marsala
5. Kadett blau
6. Blasslila

VERNI BRILLANT

(seulement Ø42 and Ø48)

1. Caramel
2. Bleu paon
3. Kaki
4. Marsala (vieux rose foncé)
5. Bleu cadet
6. Mauve

BIOMALTA FINISHED WOOD

7. light grey
8. dark grey

HOLZ BIOMALTA AUSFÜHRUNG

7. Hellgrau
8. Dunkelgrau

VENEERED WOOD

(only 120 cm and 150 cm)
9. heat-treated oak

HOLZ FURNIERT

(nur 120 cm and 150 cm)
9. thermo-behandelte Eiche

GLOSSY CERAMIC

10. Calacatta
11. Paonazzetto

GLÄNZEND KERAMIC

10. Calacatta
11. Paonazzetto

MAT CERAMIC

12. Graphitgrau
13. iridium white

MATT KERAMIC

12. Graphitgrau
13. Iridium Weiss

GLOSSY OR MAT MARBLE

(only 120 cm and 150 cm)
14. Calacatta
15. Carrara
16. Marquinia
17. Emperador

GLÄNZEND ODER MATT MARMOR

(nur 120 cm and 150 cm)
14. Calacatta
15. Carrara
16. Marquinia
17. Emperador

BOIS PLAQUÉ

(seulement 120 cm and 150 cm)
9. rouvre traité thermiquement

CÉRAMIQUE BRILLANT

10. Calacatta
11. Paonazzetto

CÉRAMIQUE OPAQUE

12. gris graphite
13. blanc iridium

MARBRE BRILLANT OU OPAQUE

(seulement 120 cm and 150 cm)
14. Calacatta
15. Carrara
16. Marquinia
17. Emperador

DIMENSIONI / DIMENSIONS / GRÖßEN / DIMENSIONS

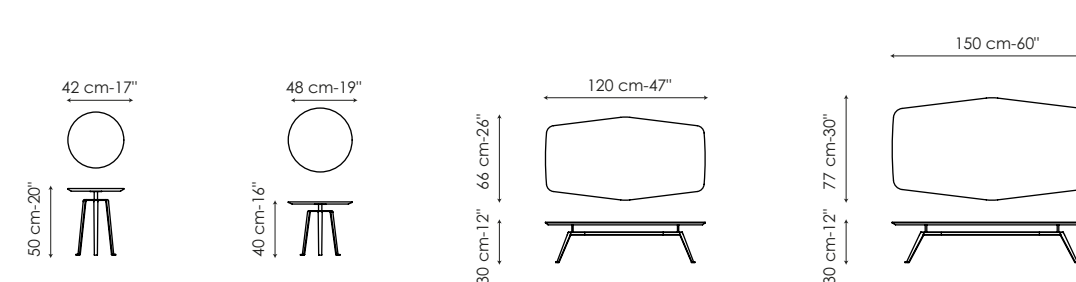

VANITY, HARRY, FORTUNY



①

FINITURA STRUTTURA / FRAME FINISH / GESTELL AUSFÜHRUNG / FINITION STRUCTURE

VERNICIATO

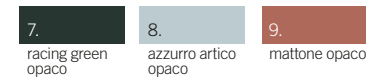
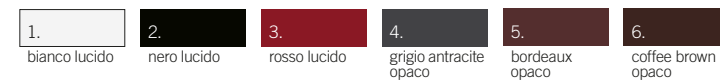

PAINTED

- glossy white
- glossy black
- glossy red
- mat anthracite grey
- mat bordeaux
- mat coffee brown
- mat racing green
- mat arctic blue
- mat brick red

LACKIERT

- Weiss glänzend
- Schwarz glänzend
- Rot glänzend
- Anthrazitgrau matt
- bordeaux matt
- coffee brown matt
- racing green matt
- arctic blue matt
- brick red matt

VERNI

- blanc brillant
- noir brillant
- rouge brillant
- gris anthracite opaque
- bordeaux opaque
- coffee brown opaque
- racing green opaque
- bleu artique opaque
- brique opaque

DIMENSIONI / DIMENSIONS / GRÖßEN / DIMENSIONS

* 44 cm - 18"
55 cm - 22"

VANITY

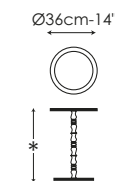

HARRY

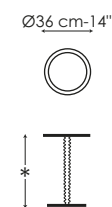

FORTUNY

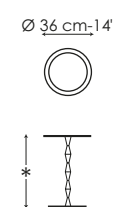

VOILÀ



①

FINITURA STRUTTURA / FRAME FINISH / GESTELL AUSFÜHRUNG / FINITION STRUCTURE

VERNICIATO OPACO

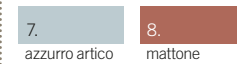
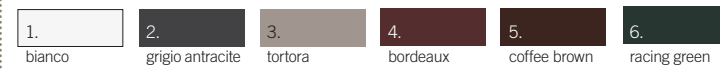

PAINTED MAT

- white
- anthracite grey
- dove grey
- bordeaux
- coffee brown
- racing green
- arctic blue
- brick red

LACKIERT MATT

- Weiss
- Anthrazitgrau
- Taubengrau
- bordeaux
- coffee brown
- racing green
- arctic blue
- brick red

VERNI OPAQUE

- blanc
- gris anthracite
- gris tourterelle
- bordeaux
- coffee brown
- racing green
- bleu artique
- brique

DIMENSIONI / DIMENSIONS / GRÖßEN / DIMENSIONS

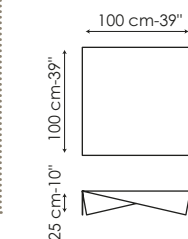

MAGAZINE BAG



①

FINITURA STRUTTURA / FRAME FINISH / GESTELL AUSFÜHRUNG / FINITION STRUCTURE

VERNICIATO OPACO



MAT PAINTED

- white
- black
- anthracite grey
- red
- dove grey
- brown
- green
- blue
- safron yellow
- mint green
- orange
- bordeaux
- coffee brown
- racing green
- arctic blue
- brick red

LACKIERT MATT

- Weiss
- Schwarz
- Anthrazitgrau
- Rot
- Taubengrau
- Braun
- Grün
- Blau
- Safrangelb
- Mintzgrün
- Orange
- bordeaux
- coffee brown
- racing green
- arctic blue
- brick red

VERNI OPAQUE

- blanc
- noir
- gris anthracite
- rouge
- gris tourterelle
- marron
- vert
- bleu
- jaune safran
- vert menthe
- orange
- bordeaux
- coffee brown
- racing green
- bleu artique
- brique

DIMENSIONI / DIMENSIONS / GRÖßEN / DIMENSIONS

SMALL

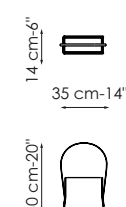

MEDIUM

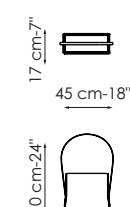

LARGE

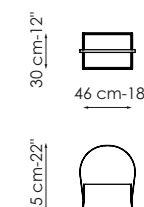

APRIL, MAY, JUNE



① FINITURA STRUTTURA / FRAME FINISH / GESTELL AUSFÜHRUNG / FINITION STRUCTURE

VERNICIATO OPACO

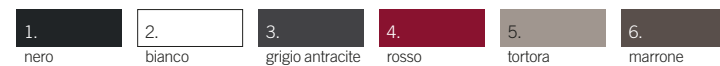

MAT PAINTED

- black
- white
- anthracite grey
- red
- dove grey
- brown
- powder pink
- green
- blue
- saffron yellow
- mint green
- bordeaux
- coffee brown
- racing green
- arctic blue
- brick red

LACKIERT MATT

- Schwarz
- Weiss
- Anthrazitgrau
- Rot
- Taubengrau
- Braun
- Puderosa
- Grün
- Blau
- Safrangelb
- Minzgrün
- bordeaux
- coffee brown
- racing green
- arctic blue
- brick red

VERNI OPAQUE

- noir
- blanc
- gris anthracite
- rouge
- gris tourterelle
- marron
- rouse poudré
- vert
- bleu
- jaune safran
- vert menthe
- bordeaux
- coffee brown
- racing green
- bleu arctique
- brique

DIMENSIONI / DIMENSIONS / GRÖßEN / DIMENSIONS

APRIL

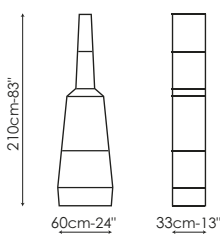

MAY

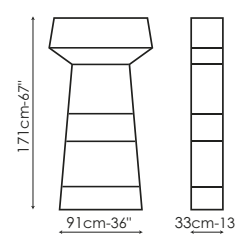

JUNE

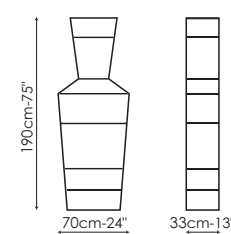

CUBIC, CUBIC GLASS

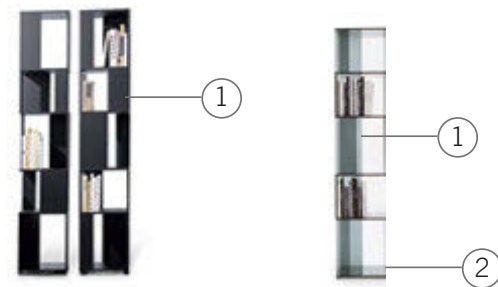

① FINITURA STRUTTURA / FRAME FINISH / GESTELL AUSFÜHRUNG / FINITION STRUCTURE

CUBIC

LACCATO OPACO



LACQUERED MAT

- black
- white

LACKIERT MATT

- Schwarz
- Weiss

LAQUÉ OPAQUE

- noir
- blanc

FINITURA STRUTTURA / FRAME FINISH / GESTELL AUSFÜHRUNG / FINITION STRUCTURE

CUBIC GLASS

CRISTALLO

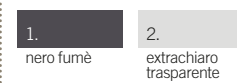

GLASS

- smoked black
- transparent extra-light

GLAS

- Rauchschwarz
- Klarglas extra-hell

CRISTAL

- noir fumé
- extra-clair transparent

② FINITURA BASE / BASE FINISH / BASIS AUSFÜHRUNG / FINITION BASE

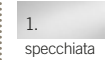

- mirror finish

- Verspiegelt

- à miroir

DIMENSIONI / DIMENSIONS / GRÖßEN / DIMENSIONS

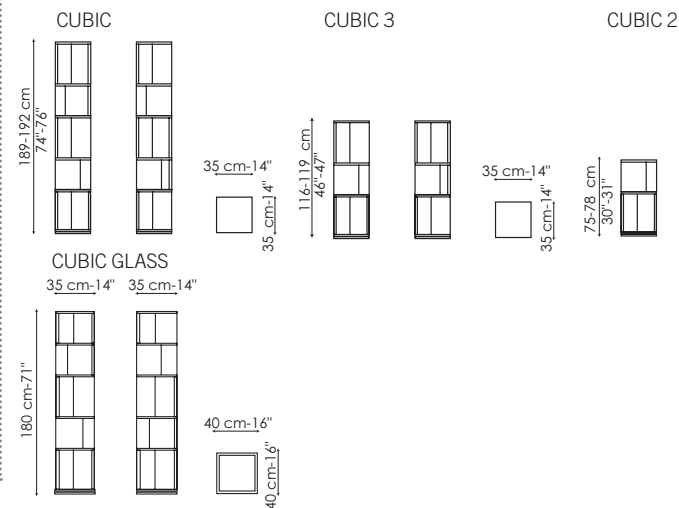

FUN



① FINITURA STRUTTURA / FRAME FINISH / GESTELL AUSFÜHRUNG / FINITION STRUCTURE

LACCATO OPACO



LACQUERED MAT

- black
- lacquered mat white

LACKIERT MATT

- Schwarz
- Lackiert Weiss

LAQUÉ OPAQUE

- noir
- blanc

DIMENSIONI / DIMENSIONS / GRÖßEN / DIMENSIONS

* 28 cm / 38 cm - 11" / 15" profondità / depth / tiefe / profondeur

FUN

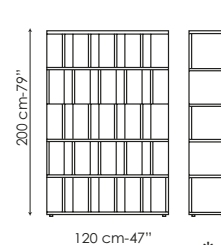

FUN 3

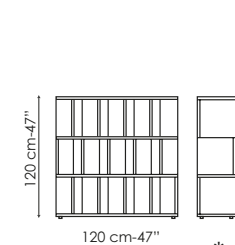

FUN 2

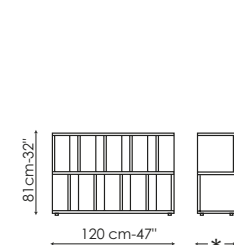

NOTE

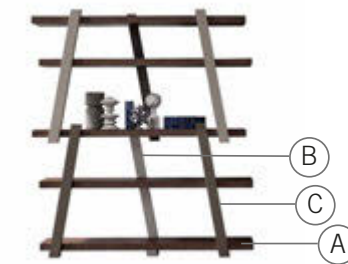

① FINITURA PIANI(A) E ASSI (B-C) / TOPS(A) AND BEAMS (B-C) FINISH / PLATTE(A) UND STÜTZSTREBEN (B-C) AUSFÜHRUNG / FINITION PLAN(A) ET AXES (B-C)

FINITURA

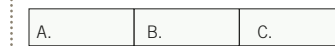

COMBINAZIONE 1
piani: laccato bianco opaco (A)
assi: laccato bianco opaco (B-C)

COMBINAZIONE 2
piani: laccato grigio quarzo opaco (A)
assi: laccato grigio quarzo opaco (B-C)



COMBINAZIONE 3
piani: impiallacciato noce americano (A)
assi: laccato tortora opaco (B), laccato marrone opaco (C)



COMBINAZIONE 6
piani: Rovere termotrattato (A)
assi: laccato tortora opaco (B), laccato marrone opaco (C)

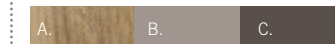

COMBINAZIONE 7
piani: impiallacciato rovere naturale (A)
assi: laccato tortora opaco (B), laccato marrone opaco (C)

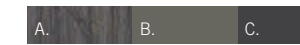

COMBINAZIONE 8:
piani: impiallacciato rovere grigio (A)
assi: laccato grigio quarzo opaco (B), laccato grigio antracite opaco (C)

COMBINAZIONE 1
tops: mat lacquered white (A)
beams: mat lacquered white (B-C)

KOMBINATION 1
Platte: Weiss Lackiert matt (A)
Stützs.: Weiss Lackiert matt (B-C)

COMBINAISON 1
plan: laqué blanc opaque (A)
axes: laqué blanc opaque (B-C)

COMBINAZIONE 2
tops: mat lacquered quartz grey (A)
beams: mat lacquered quartz grey (B-C)

KOMBINATION 2
Platte: Grau Quarz Lackiert matt (A)
Stützs.: Grau Quarz Lackiert matt (B-C)

COMBINAISON 2
plan: laqué gris quartz opaque (A)
axes: laqué gris quartz opaque (B-C)

COMBINAZIONE 3
tops: veneered wood american walnut (A)
beams: mat lacquered dove grey (B), mat lacquered brown (C)

KOMBINATION 3
Platte: Holz furniert Amerikaner Nussbaum (A)
Stützs.: Taubengrau Lackiert matt (B), Braun Lackiert matt (C)

COMBINAISON 3
plan: bois plaqué noyer américain (A)
axes: laqué gris tourterelle opaque (B), laqué marron opaque (C)

COMBINAZIONE 6
tops: heat-treated oak (A)
beams: mat lacquered dove grey (B), mat lacquered brown (C)

KOMBINATION 6
Platte: thermo-behandeltes Eiche (A)
Stützs.: Taubengrau Lackiert matt (B), Braun Lackiert matt (C)

COMBINAISON 6
plan: rouvre traité thermiquement (A)
axes: laqué gris tourterelle opaque (B), laqué marron opaque (C)

COMBINAZIONE 7
tops: natural oak (A)
beams: mat lacquered dove grey (B), mat lacquered brown (C)

KOMBINATION 7
platte: Eiche Natur (A)
Stützs.: Taubengrau Lackiert matt (B), Braun Lackiert matt (C)

COMBINATION 7
plan: rouvre naturel (A)
axes: laqué gris tourterelle opaque (B), laqué marron opaque (C)

COMBINAZIONE 8
tops: grey oak (A)
beams: mat lacquered quartz grey (B), mat lacquered anthracite grey (C)

KOMBINATION 8
platte: Eiche Anthrazitgrau (A)
Stützs.: Grau Quarz Lackiert matt (B), Anthrazitgrau Lackiert matt (C)

COMBINATION 8
plan: rouvre gris anthracite (A)
axes: laqué gris quartz opaque (B), laqué gris anthracite opaque (C)

DIMENSIONI / DIMENSIONS / GRÖßEN / DIMENSIONS

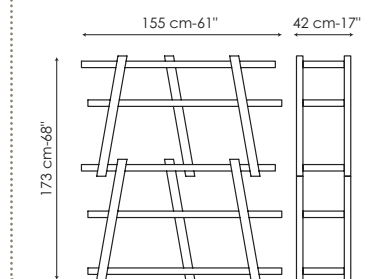

UP AND DOWN, UP AND DOWN LIGHT

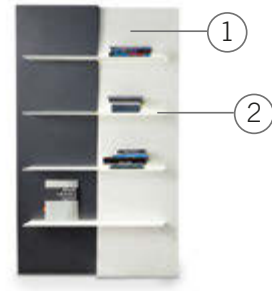

①

FINITURA STRUTTURA / FRAME FINISH / GESTELL AUSFÜHRUNG / FINITION STRUCTURE

LACCATO OPACO



LACQUERED MAT

- 1. white / white
- 2. white / anthracite grey

LACKIERT MATT

- 1. Weiss / Weiss
- 2. Weiss / Anthrazitgrau

LAQUÉ OPAQUE

- 1. blanc / blanc
- 2. blanc /gris anthracite

②

FINITURA RIPIANI / SHELVES FINISH / FACHBODEN AUSFÜHRUNG / FINITION RAYONS

CRISTALLO

- 1. extrachiaro acidato verniciato bianco

GLASS

- 1. extra-light acid-treated painted white

GLAS

- 1. Geätztes extra-hell weiss

CRISTAL

- 1. extra-clair traité à l'acide verni blanc

DIMENSIONI / DIMENSIONS / GRÖßEN / DIMENSIONS

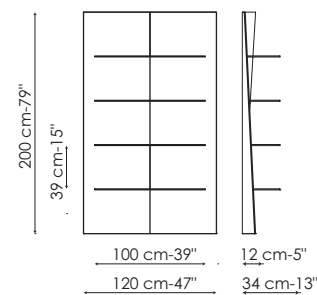

EOS, EOS LIGHT

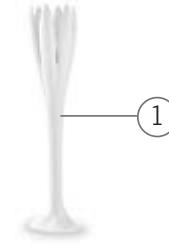

①

FINITURA STRUTTURA / FRAME FINISH / GESTELL AUSFÜHRUNG / FINITION STRUCTURE

EOS
POLIETILENE OPACO

- 1. bianco

POLYETHYLENE MAT

- 1. white

POLYETHYLEN MATT

- 1. Weiss

POLYÉTHYLÈNE OPAQUE

- 1. blanc

EOS LIGHT

POLIETILENE

- 1. bianco opaco con luce a fluorescenza

POLYETHYLENE MAT

- 1. white with fluorescent light

POLYETHYLEN MATT

- 1. Weiss mit Fluoreszenzlampe

POLYÉTHYLÈNE OPAQUE

- 1. blanc avec lumière fluorescente

DIMENSIONI / DIMENSIONS / GRÖßEN / DIMENSIONS

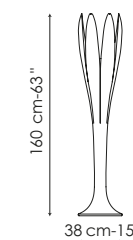

KADOU, KADOU LIGHT



①

FINITURA STRUTTURA / FRAME FINISH / GESTELL AUSFÜHRUNG / FINITION STRUCTURE

KADOU
POLIETILENE

- 1. bianco
- 2. grigio antracite
- 3. tortora
- 4. bronzo

POLYETHYLENE MAT

- 1. white
- 2. anthracite grey
- 3. dove grey
- 4. bronze

POLYETHYLEN MATT

- 1. Weiss
- 2. Anthrazitgrau
- 3. Taubengrau
- 4. Bronze

POLYÉTHYLÈNE OPAQUE

- 1. blanc
- 2. gris anthracite
- 3. gris tourterelle
- 4. bronze

KADOU LIGHT

POLIETILENE

- 1. bianco opaco con luce a fluorescenza

POLYETHYLENE MAT

- 1. white with fluorescent light

POLYETHYLEN MATT

- 1. Weiss mit Fluoreszenzlampe

POLYÉTHYLÈNE OPAQUE

- 1. blanc avec lumière fluorescente

②

FINITURA RAMI / BRANCHES FINISH / ÄSTE AUSFÜHRUNG / FINITION BRAS

VERNICIATO OPACO

- 1. bianco
- 2. grigio antracite
- 3. tortora
- 4. rosso corallo
- 5. arancio
- 6. verde

7.

avorio

8.

rosa cipria

9.

marrone

MAT PAINTED

- 1. white
- 2. anthracite grey
- 3. dove grey
- 4. coral red
- 5. orange
- 6. green
- 7. ivory
- 8. powder pink
- 9. brown

MATT LACKIERT

- 1. Weiss
- 2. Anthrazitgrau
- 3. Taubengrau
- 4. Korallenrot
- 5. Orange
- 6. Grün
- 7. Elfenbeinweiss
- 8. Puderrosa
- 9. Braun

VERNI OPAQUE

- 1. blanc
- 2. gris anthracite
- 3. gris tourterelle
- 4. rouge corail
- 5. orange
- 6. vert
- 7. ivoire
- 8. rose poudré
- 9. marron

DIMENSIONI / DIMENSIONS / GRÖßEN / DIMENSIONS

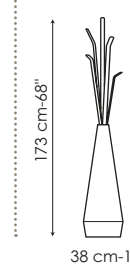

MUFFIN LAMP

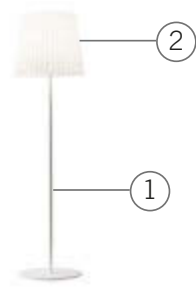

①
FINITURA STRUTTURA / FRAME FINISH / GESTELL AUSFÜHRUNG / FINITION STRUCTURE

METALLO VERNICIATO OPACO

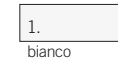

1. bianco

MAT PAINTED
 1. white

LACKIERT MATT
 1. Weiss

VERNI OPAQUE
 1. blanc

②
PARALUME / LAMPSHADE / LAMPENSCHIRM / PARALUME

POLIETILENE OPACO



1. bianco

MAT POLYETHYLENE
 1. white

POLYETHYLEN MATT
 1. Weiss

POLYÉTHYLÈNE OPAQUE
 1. blanc

DIMENSIONI / DIMENSIONS / GRÖßEN / DIMENSIONS

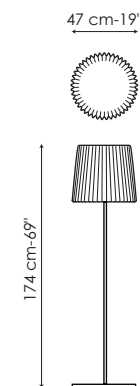

TREE, TREE LIGHT

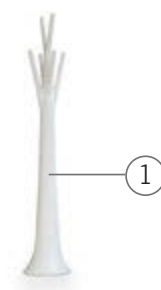

①
FINITURA STRUTTURA / FRAME FINISH / GESTELL AUSFÜHRUNG / FINITION STRUCTURE

TREE

POLIETILENE OPACO

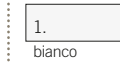

1. bianco



2. grigio antracite



3. tortora



4. arancio



5. verde



6. rosso



7. giallo

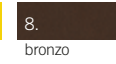

8. bronzo

POLIETILENE LUCIDO LACCATO



1. bianco



2. nero

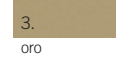

3. oro

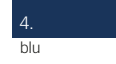

4. blu



5. argento



6. viola

POLYETHYLENE MAT

- 1. white
- 2. anthracite grey
- 3. dove grey
- 4. orange
- 5. green
- 6. red
- 7. yellow
- 8. bronze

POLYETHYLEN MATT

- 1. Weiss
- 2. Anthrazitgrau
- 3. Taubengrau
- 4. Orange
- 5. Grün
- 6. Rot
- 7. Gelb
- 8. Bronze

POLYÉTHYLÈNE OPAQUE

- 1. blanc
- 2. gris anthracite
- 3. gris tourterelle
- 4. orange
- 5. vert
- 6. rouge
- 7. jaune
- 8. bronze

LACQUERED GLOSSY

- 9. white
- 10. black
- 11. gold
- 12. blue
- 13. silver
- 14. violet

LACKIERT GLÄNZEND

- 9. Weiss
- 10. Schwarz
- 11. Gold
- 12. Blau
- 13. Silber
- 14. Violett

LAQUÉ BRILLANT

- 9. blanc
- 10. noir
- 11. or
- 12. bleu
- 13. argent
- 14. violet

TREE LIGHT

POLIETILENE

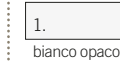

1. bianco opaco con luce a fluorescenza

POLYETHYLENE MAT

- 1. white with fluorescent light

POLYETHYLEN MATT

- 1. Weiss mit Fluoreszenzlampe

POLYÉTHYLÈNE OPAQUE

- 1. blanc avec lumière fluorescente

DIMENSIONI / DIMENSIONS / GRÖßEN / DIMENSIONS

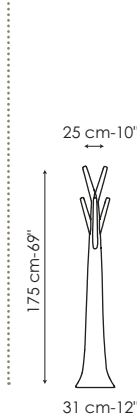

XXLIGHT

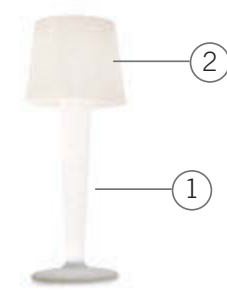

①
FINITURA STRUTTURA / FRAME FINISH / GESTELL AUSFÜHRUNG / FINITION STRUCTURE

POLIETILENE OPACO

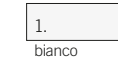

1. bianco

MAT PAINTED
 1. white

LACKIERT MATT
 1. Weiss

VERNI OPAQUE
 1. blanc

②
PARALUME / LAMPSHADE / LAMPENSCHIRM / PARALUME

POLICARBONATO OPACO



1. bianco

MAT POLYCARBONATE
 1. white

POLIKARBONAT MATT
 1. Weiss

POLICARBONATE OPAQUE
 1. blanc

DIMENSIONI / DIMENSIONS / GRÖßEN / DIMENSIONS

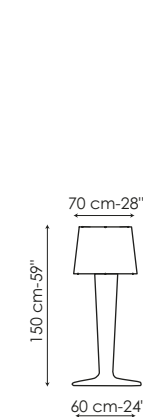

AMOND MIRROR



①

FINITURA BORDO A / EDGE A FINISH / RAHMEN A AUSFÜHRUNG / FINITION BORD A

VERNICIATO OPACO

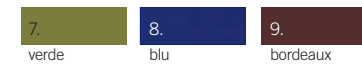
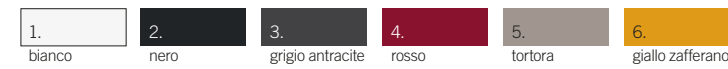

METALLO FINITURA



MAT PAINTED

- white
- black
- anthracite grey
- red
- dove grey
- saffron yellow
- green
- blue
- bordeaux

LACKIERT MATT

- Weiss
- Schwarz
- Anthrazitgrau
- Rot
- Taubengrau
- Saafuangelb
- Grün
- Blau
- Bordeaux

VERNI OPAQUE

- blanc
- noir
- gris anthracite
- rouge
- gris tourterelle
- jaune safran
- vert
- bleu
- bordeaux

METAL FINISH

- copper
- brass
- pickled

METALL AUSFÜHRUNG

- Kupfer
- Messing
- Stahlgrau

FINITION MÉTAL

- cuivre
- laiton
- décapé

②

FINITURA BORDO B / EDGE B FINISH / RAHMEN B AUSFÜHRUNG / FINITION BORD B

LEGNO IMPIALLACCIATO



VENEREED WOOD

- walnut canaletto
- natural polished oak
- anthracite grey polished oak

HOLZ FURNIERT

- Nussbaum Canaletto
- Eiche Natur poliert
- Eiche Anthrazitgrau poliert

BOIS PLAQUÉ

- noyer canaletto
- rovere brossé naturel
- rovere brossé gris anthracite

DIMENSIONI / DIMENSIONS / GRÖßEN / DIMENSIONS

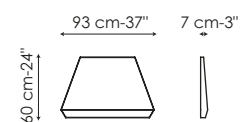

AX MIRROR



①

FINITURA STRUTTURA / FRAME FINISH / GESTELL AUSFÜHRUNG / FINITION STRUCTURE

VERNICIATO OPACO



METALLO FINITURA

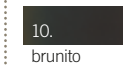

MAT PAINTED

- white
- black
- anthracite grey
- red
- dove grey
- saffron yellow
- green
- blue
- bordeaux

LACKIERT MATT

- Weiss
- Schwarz
- Anthrazitgrau
- Rot
- Taubengrau
- Saafuangelb
- Grün
- Blau
- Bordeaux

VERNI OPAQUE

- blanc
- noir
- gris anthracite
- rouge
- gris tourterelle
- jaune safran
- vert
- bleu
- bordeaux

METAL FINISH

- burnished

METALL AUSFÜHRUNG

- Brüniert

FINITION MÉTAL

- bruni

DIMENSIONI / DIMENSIONS / GRÖßEN / DIMENSIONS

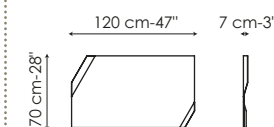

AZERO



①

FINITURA STRUTTURA / FRAME FINISH / GESTELL AUSFÜHRUNG / FINITION STRUCTURE

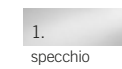

1. mirror

1. Spiegel

1. miroir

DIMENSIONI / DIMENSIONS / GRÖßEN / DIMENSIONS

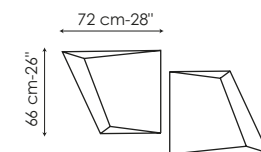

ECLIPSE



①

FINITURA STRUTTURA / FRAME FINISH / GESTELL AUSFÜHRUNG / FINITION STRUCTURE

LACCATO OPACO

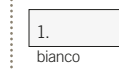

1. bianco

DIMENSIONI / DIMENSIONS / GRÖßEN / DIMENSIONS

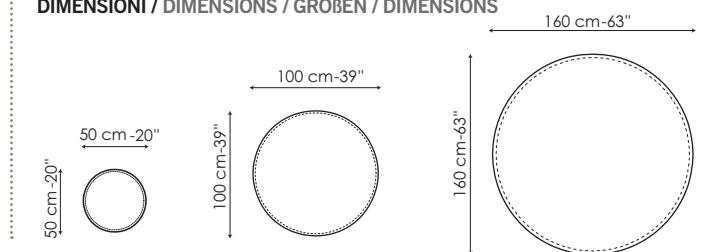

HANG UP

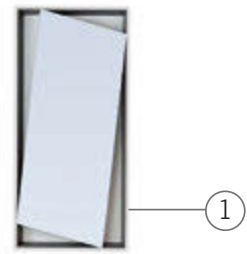

①
FINITURA STRUTTURA / FRAME FINISH / GESTELL AUSFÜHRUNG / FINITION STRUCTURE

LACCATO OPACO

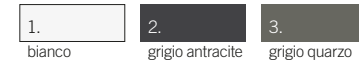

LEGNO MASSELLO



LACQUERED

1. mat white
2. mat anthracite grey
3. mat quartz grey

SOLID WOOD

4. ash polished white
5. ash polished grey
6. walnut painted ash

LACKIERT

1. Weiss matt
2. Anthrazitgrau matt
3. Grau Quarz matt

MASSIVHOLZ

4. Eschen Weiss poliert
5. Eschen Grau poliert
6. Esche nussbaumfarbig lackiert

LAQUÉ

1. blanc opaque
2. gris anthracite opaque
3. gris quartz opaque

BOIS MASSIF

4. frêne blanc brossé
5. frêne gris brossé
6. frêne teinté noyer

DIMENSIONI / DIMENSIONS / GRÖßEN / DIMENSIONS

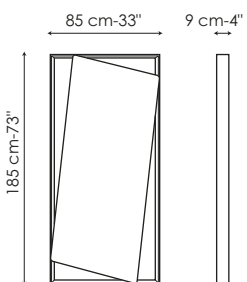

NEW PERSPECTIVE MIRROR

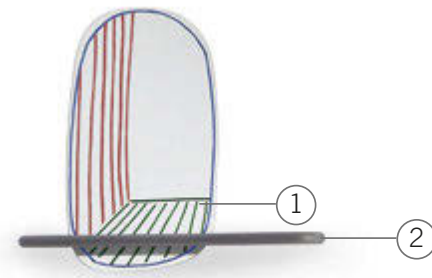

①
FINITURA DECORO / DECOR FINISH / DEKOR AUSFÜHRUNG / STRUCTURE



COMBINATION 1

1. red, green, blue

COMBINATION 2

2. black

COMBINATION 3

3. copper

KOMBINATION 1

1. Rot, Grün, Blau

KOMBINATION 2

2. Schwarz

KOMBINATION 3

3. Kupfer

COMBINAISON 1

1. rouge, vert, bleu

COMBINAISON 2

2. noir

COMBINAISON 3

3. cuivre

②
FINITURA MENSOLA / SHELF FINISH / REGAL AUSFÜHRUNG / ÉTAGÈRE STRUCTURE
(solo per / only for / nur für / seulement New perspective mirror small)

LEGNO MASSELLO



SOLID WOOD

1. anthracite grey polished oak

MASSIVHOLZ

1. Eiche Anthrazitgrau poliert

BOIS MASSIF

1. rouvre brossé gris anthracite

DIMENSIONI / DIMENSIONS / GRÖßEN / DIMENSIONS

NEW PERSPECTIVE MIRROR SMALL

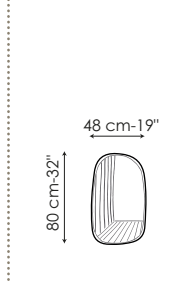

NEW PERSPECTIVE MIRROR SMALL con mensola / with shelf / mit Regal / avec étagère

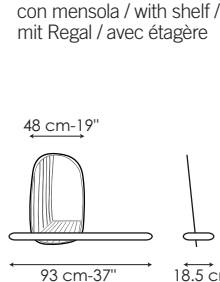

NEW PERSPECTIVE MIRROR LARGE

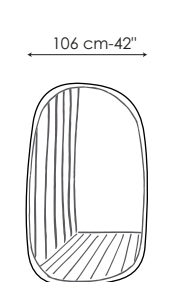

OBEL



①
FINITURA STRUTTURA / FRAME FINISH / GESTELL AUSFÜHRUNG / FINITION STRUCTURE

LEGNO MASSELLO



SOLID WOOD

1. American walnut
2. natural ash
3. ash grey

MASSIVHOLZ

1. Amerikaner Nussbaum
2. Eschenholz Natur
3. Eschenholz Grau

BOIS MASSIF

1. noyer américain
2. Eschenholz Natur
3. Eschenholz Grau

DIMENSIONI / DIMENSIONS / GRÖßEN / DIMENSIONS

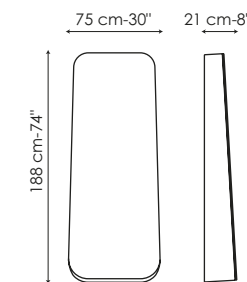

PIERS

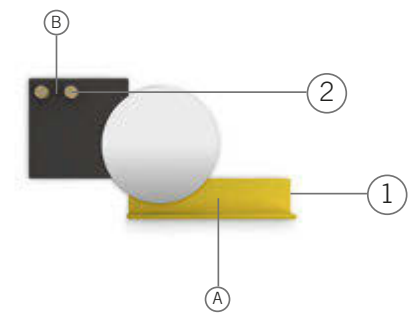

①
FINITURA STRUTTURA / FRAME FINISH / GESTELL AUSFÜHRUNG / FINITION STRUCTURE

LACCATO OPACO

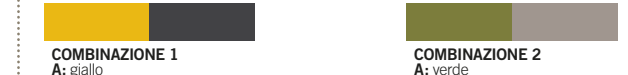

COMBINAZIONE 3

- A: rosa cipria
- B: amaranto

COMBINAZIONE 4

- A: arancio
- B: tortora

MAT LACQUERED

COMBINATION 1

- A: yellow
- B: anthracite grey

COMBINATION 2

- A: green
- B: dove grey

COMBINATION 3

- A: powder pink
- B: amaranth

COMBINATION 4

- A: orange
- B: dove grey

LACKIERT MATT

KOMBINATION 1

- A: Gelb
- B: Anthrazitgrau

KOMBINATION 2

- A: Grün
- B: Taubengrau

KOMBINATION 3

- A: Pudderosa
- B: Amaranth

KOMBINATION 4

- A: Orange
- B: Taubengrau

LAQUÉ OPAQUE

COMBINAISON 1

- A: jaune
- B: gris anthracite

COMBINAISON 2

- A: vert
- B: gris tourterelle

COMBINAISON 3

- A: rose poudré
- B: amarante

COMBINAISON 4

- A: orange
- B: gris tourterelle

②
FINITURA POMELLI / KNOBS FINISH / KNÖPFTE AUSFÜHRUNG / FINITION BOUTONES

LEGNO MASSELLO



SOLID WOOD

1. natural ash

MASSIVHOLZ

1. Eschenholz Natur

BOIS MASSIF

1. Eschenholz Natur

DIMENSIONI / DIMENSIONS / GRÖßEN / DIMENSIONS

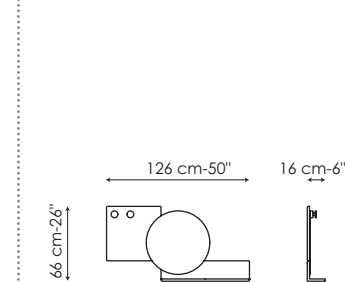

SPIRAL MIRROR

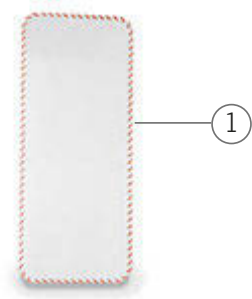

① **FINITURA CORDINO / CORD FINISH / KEDER AUSFÜHRUNG / FINITION PASSE POIL**



- | | | |
|--------------------|------------------|---------------------|
| 1. white | 1. Weiss | 1. blanc |
| 2. anthracite grey | 2. Anthrazitgrau | 2. gris anthracite |
| 3. red | 3. Rot | 3. rouge |
| 4. dove grey | 4. Taubengrau | 4. gris tourterelle |

DIMENSIONI / DIMENSIONS / GRÖßEN / DIMENSIONS

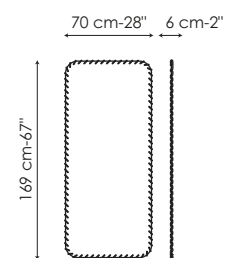

CUBE



① **FINITURA RIVESTIMENTO / UPHOLSTERED FINISH / BEZUG AUSFÜHRUNG / FINITION REVÊTEMENT**

RIVESTIMENTO
pelle
ecopelle
tessuto

UPHOLSTERY
leather
eco-leather
fabric

BEZUG
Leder
Kunstleder
Stoff

REVÊTEMENT
cuir souple
éco-cuir
tissu

DIMENSIONI / DIMENSIONS / GRÖßEN / DIMENSIONS

CUBE SMALL

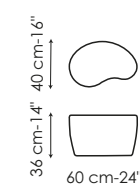

CUBE BIG

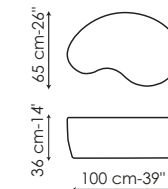

HOLLYWOOD



① **FINITURA RIVESTIMENTO / UPHOLSTERED FINISH / BEZUG AUSFÜHRUNG / FINITION REVÊTEMENT**

TESSUTO ELASTICO

- 422 bianco
- 418 rosa
- 426 fucsia
- 413 rosso
- 424 arancio
- 423 giallo
- 420 viola
- 421 verde
- 425 azzurro
- 416 blu
- 417 marrone
- 415 grigio antracite
- 419 nero
- limited edition

STRETCH FABRIC

- 422 white
- 418 pink
- 426 fuchsia
- 413 red
- 424 orange
- 423 yellow
- 420 violet
- 421 green
- 425 light blue
- 416 blue
- 417 brown
- 415 anthracite grey
- 419 black
- limited edition

ELASTISCHER STOFF

- 422 Weiss
- 418 Rosa
- 426 Fuchsinrot
- 413 Rot
- 424 Orange
- 423 Gelb
- 420 Violett
- 421 Grün
- 425 Hellblau
- 416 Blau
- 417 Braun
- 415 Anthrazitgrau
- 419 Schwarz
- limited edition

TISSU ÉLASTIQUE

- 422 blanc
- 418 rose
- 426 Fuchsia
- 413 rouge
- 424 orange
- 423 jaune
- 420 violet
- 421 vert
- 425 bleu clair
- 416 bleu
- 417 marron
- 415 gris anthracite
- 419 noir
- limited edition

DIMENSIONI / DIMENSIONS / GRÖßEN / DIMENSIONS

HOLLYWOOD MEDIUM

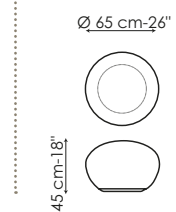

HOLLYWOOD LARGE

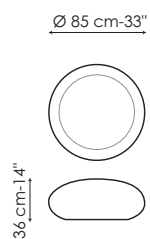

PEBBLE POUF



①

FINITURA STRUTTURA / FRAME FINISH / GESTELL AUSFÜHRUNG / FINITION STRUCTURE

POLIETILENE OPACO
ESTERNO - INTERNO



MAT POLYETHYLENE
OUTSIDE - INSIDE

1. white - white
2. white - anthracite grey
3. white - powder blue
4. red - white
5. anthracite grey - white
6. powder blue - white

POLYETHYLEN MATT
AUSSEN - INNEN

1. Weiss - Weiss
2. Weiss - Anthrazitgrau
3. Weiss - Pulverblau
4. Rot - Weiss
5. Anthrazitgrau - Weiss
6. Pulverblau - Weiss

POLYÉTHYLÈNE OPAQUE
EXTÉRIEUR - INTÉRIEUR

1. blanc - blanc
2. blanc - gris anthracite
3. blanc - bleu poudre
4. rouge - blanc
5. gris anthracite - blanc
6. bleu poudre - blanc

DIMENSIONI / DIMENSIONS / GRÖßEN / DIMENSIONS

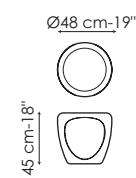

PANORAMA



①

FINITURA STRUTTURA / FRAME FINISH / GESTELL AUSFÜHRUNG / FINITION STRUCTURE

LACCATO LUCIDO



*parte posteriore laccata opaca

LACQUERED GLOSSY

1. glossy white*
2. glossy black*

*mat lacquered back

LACKIERT GLÄNZEND

1. Weiss*
2. Schwarz*

*hintere Teil matt Lackiert

LAQUÉ BRILLANT

1. blanc*
2. noir*

*partie postérieure laqué opaque

②

FINITURA BASE / BASE FINISH / BASIS AUSFÜHRUNG / FINITION BASE

METALLO



cromato

METAL FINISH

1. chromed

METALL AUSFÜHRUNG

1. Verchromt

FINITION MÉTAL

1. chromé

DIMENSIONI / DIMENSIONS / GRÖßEN / DIMENSIONS

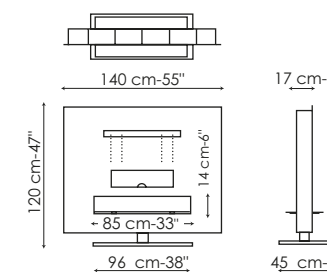

VISION



①

FINITURA STRUTTURA / FRAME FINISH / GESTELL AUSFÜHRUNG / FINITION STRUCTURE

LACCATO LUCIDO



*parte posteriore laccata opaca

LACQUERED GLOSSY

1. glossy white*
2. glossy black*

*mat lacquered back

LACKIERT GLÄNZEND

1. Weiss*
2. Schwarz*

*hintere Teil matt Lackiert

LAQUÉ BRILLANT

1. blanc*
2. noir*

*partie postérieure laqué opaque

②

FINITURA BASE / BASE FINISH / BASIS AUSFÜHRUNG / FINITION BASE

METALLO



cromato

METAL FINISH

1. chromed

METALL AUSFÜHRUNG

1. Verchromt

FINITION MÉTAL

1. chromé

DIMENSIONI / DIMENSIONS / GRÖßEN / DIMENSIONS

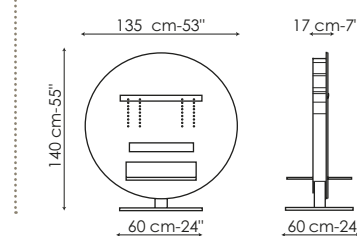

Legno / Wood / Holz / Bois



noce americano
American walnut
Amerikaner Nussbaum
noyer américain

noce canaletto
canaletto walnut
Nussbaumholz Canaletto
noyer canaletto

rovere spazzolato naturale
natural polished oak
Eiche Natur poliert
rouvre brossé naturel

rovere spazzolato termotrattato
heat-treated polished oak
thermo-behandeltes polierte Eiche
rouvre brossé thermiquement



rovere spazzolato grigio antracite
anthracite grey polished oak
Eiche Anthrazitgrau poliert
rouvre brossé gris anthracite

frassino spazzolato grigio
grey polished ash
Eschen Grau poliert
frêne brossé gris

frassino tinto noce
walnut painted ash
Eschen nussbaumfarbig lackiert
frêne teinté noyer

frassino spazzolato naturale
natural polished ash
Eschen Natur poliert
frêne naturel brossé

Biomalta



biomalta grigio chiaro
light grey biomalta
hellgrau Biomalta
biomalta gris clair

biomalta grigio scuro
dark grey biomalta
dunkelgrau Biomalta
biomalta gris foncé

Legno Laccato / Lacquered Wood / Holz Lackiert / Bois Laqué

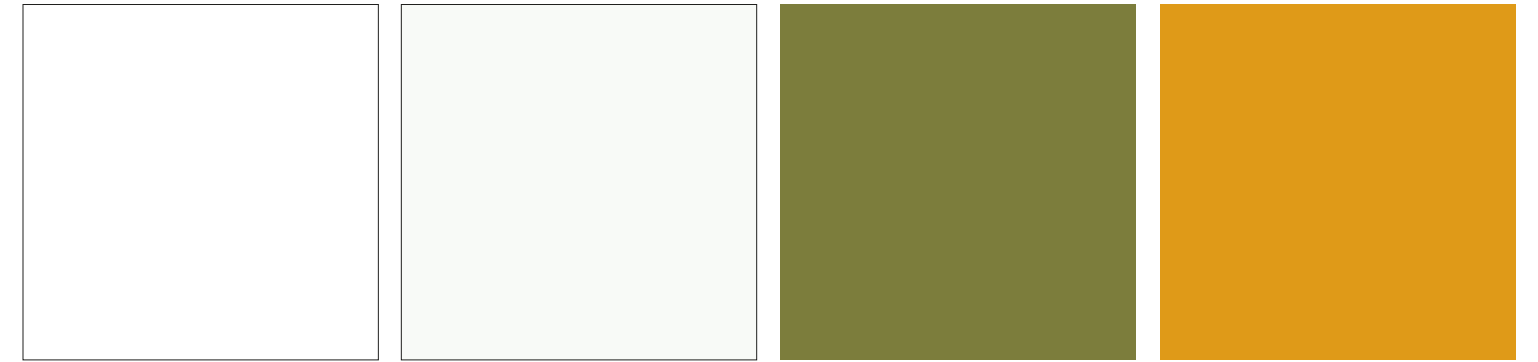

bianco lucido
glossy white
Weiss glänzend
blanc brillant

bianco opaco
mat white
Weiss matt
blanc opaque

verde opaco
mat green
Grün matt
vert opaque

giallo zafferano opaco
mat saffron yellow
Safrangelb matt
jaune safran opaque

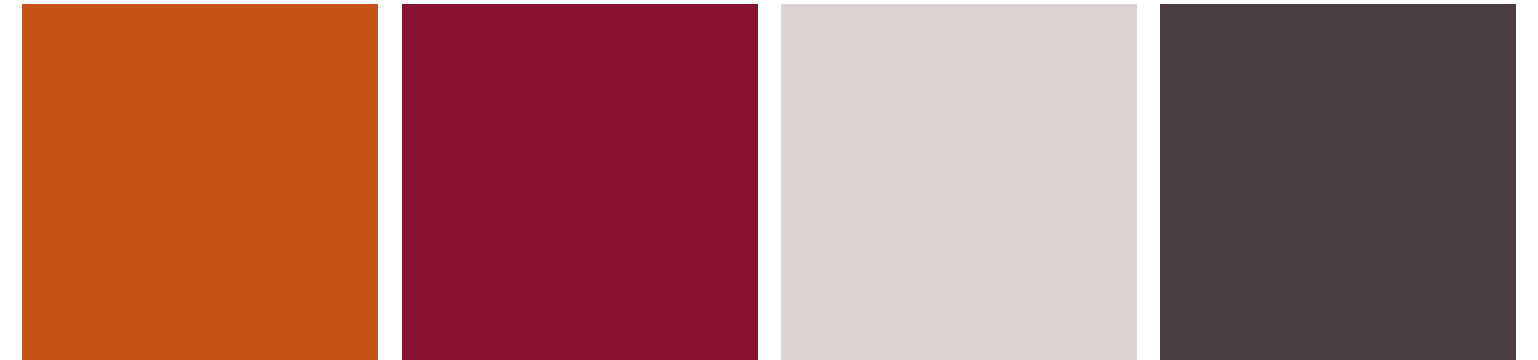

arancio opaco
mat orange
Orange matt
orange opaque

rosso opaco
mat red
Rot matt
rouge opaque

rosa cipria opaco
mat powder pink
Pudderosa matt
rose poudré opaque

amaranto opaco
mat amaranth
Amaranth matt
amarante opaque



tortora opaco
mat dove grey
Taubengrau matt
gris tourterelle opaque

grigio quarzo opaco
mat quartz grey
Grau Quarz matt
gris quartz opaque

marrone opaco
mat brown
Braun matt
marron opaque

grigio antracite opaco
mat anthracite grey
Anthrazitgrau matt
gris anthracite opaque

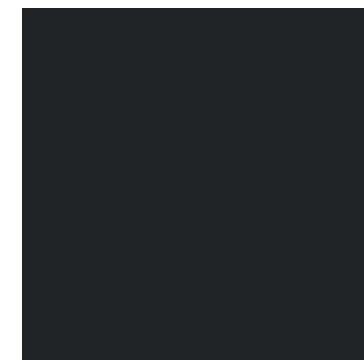

nero lucido
glossy black
Schwarz glänzend
noir brillant

Tie - Legno Laccato Lucido / Glossy Lacquered Wood / Holz Lackiert glänzend /
Bois Laqué Brillant

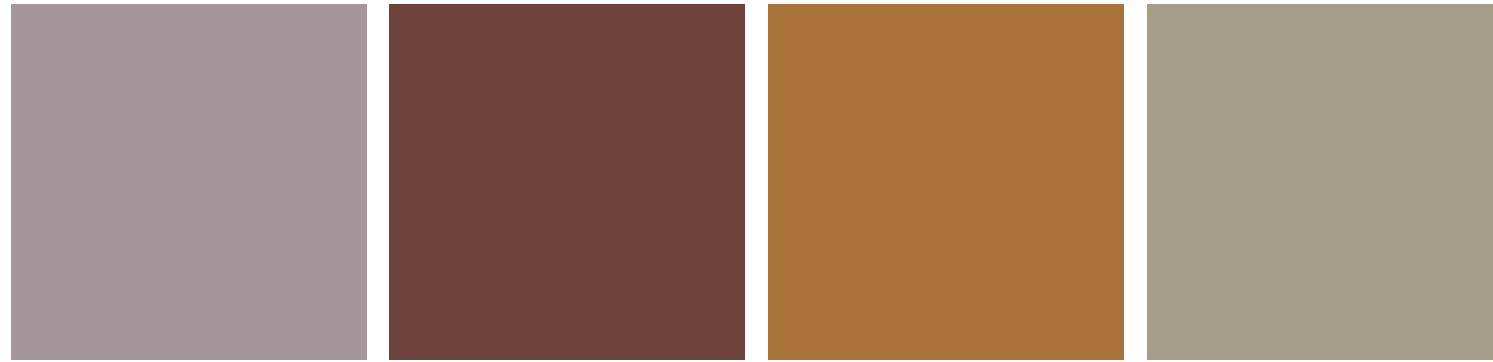

malva
mauve
Blassliila
mauve

marsala
marsala
Marsala
marsala

caramello
caramel
Karamell
Caramel

kaki
khaki
Khaki
kaki



pavone
peacock blue
Pfaunenblau
bleu paon

blu cadetto
cadet blue
Kadett blau
bleu cadet

Cristallo / Glass / Glas / Cristal



cristallo trasparente
transparent glass
Klarglas
cristal transparent

cristallo extrachiaro trasparente
extra-light transparent glass
Klarglas extra-hell
cristal extra-clair transparent

cristallo extrachiaro acidato bianco
white acid-treated extra-light glass
Geätztes Glas extra-hell Weiss
cristal extra-clair traité à l'acide blanc

cristallo extrachiaro verniciato bianco
white painted extra-light glass
Glas extra-hell Weiss lackiert
cristal extra-clair verni blanc



cristallo nero fumè
smoked black glass
Rauchschwarz Glas
cristal noir fumé

cristallo acidato nero
black acid-treated glass
Geätztes Schwarz Glas
cristal traité à l'acide noir

cristallo verniciato nero
black painted glass
Glas Schwarz lackiert
cristal verni noir

Marmo / Marble / Marmor / Marbre

disponibile nella finitura opaca o lucida / available mat or glossy / matt oder glänzend erhältlich / disponible opaque ou brillant



marmo di Carrara
Carrara marble
Carrarischer Marmor
marbre de Carrara



marmo Calacatta
Calacatta marble
Calacatta Marmor
marbre Calacatta



marmo Emperador
Emperador marble
Emperador Marmor
marbre Emperador

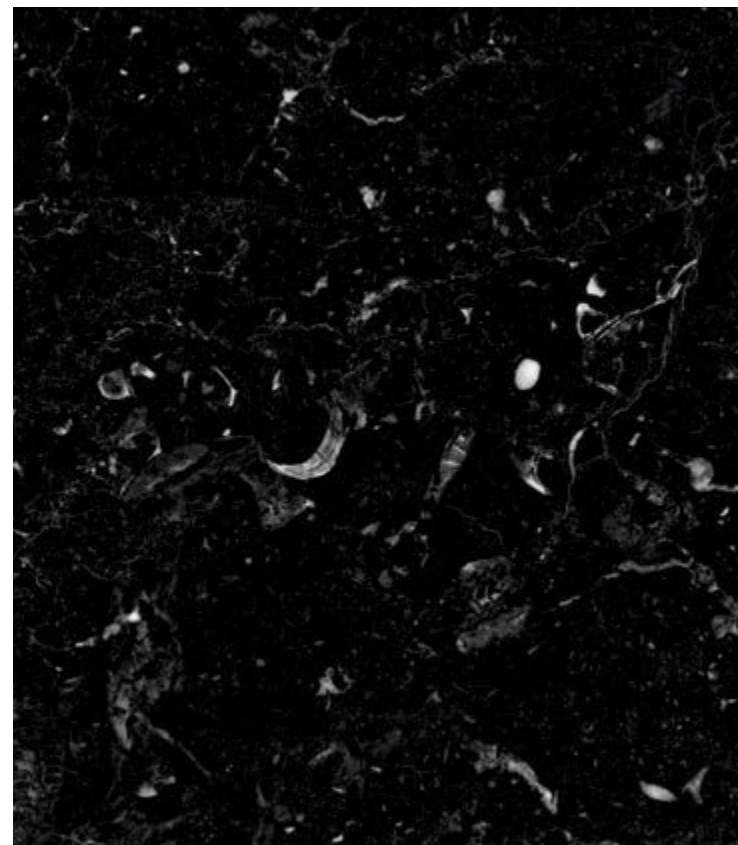

marmo Marquinia
Marquinia marble
Marquinia Marmor
marbre Marquinia

Ceramica / Ceramic / Keramik / Céramique



ceramica bianco iridium
white ceramic
Weiss Keramik
céramique blanche



ceramica grigio antracite
anthracite grey ceramic
Anthrazitgrau Keramik
céramique gris anthracite



ceramica Calacatta
Calacatta ceramic
Calacatta Keramik
céramique Calacatta



ceramica Paonazetto
Paonazetto ceramic
Paonazetto Keramik
céramique Paonazetto

Metalli / Metals / Metalle / Métaux

verniciati / painted / Lackiert / vernis

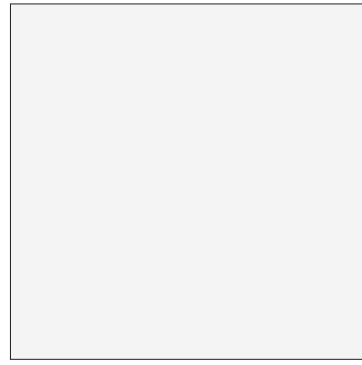

bianco lucido
glossy white
Weiss glänzend
blanc brillant

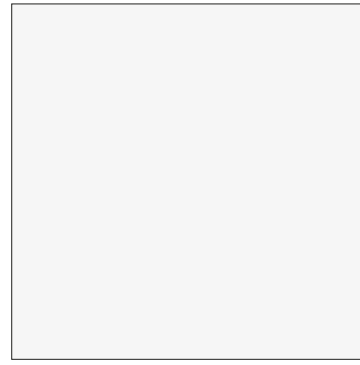

bianco opaco
mat white
Weiss matt
blanc opaque

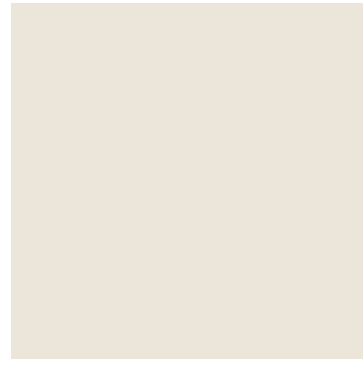

avorio opaco
mat ivory
Elfenbeinweiss matt
ivoire opaque

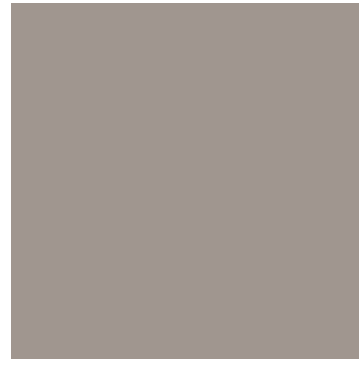

tortora opaco
mat dove grey
Taubengrau matt
gris tourterelle opaque



azzurro artico opaco
mat arctic blue
Arktisch blau matt
bleu artique opaque



blu opaco
mat blue
Blau matt
bleu opaque



blu lucido
glossy blue
Blau glänzend
bleu brillant



verde menta opaco
mat mint green
Minzgrün matt
vert menthe opaque



rosa cipria opaco
mat powered pink
Pudderosa matt
rose poudré opaque



giallo zafferano opaco
mat saffron yellow
Safrangelb matt
jaune safran opaque



arancio opaco
mat orange
Orange matt
orange opaque



mattone opaco
mat brick red
Ziegelrot matt
brique opaque



verde opaco
mat green
Grün matt
vert opaque



racing green opaco
mat racing green
Racing green matt
racing green opaque



grigio antracite opaco
mat anthracite grey
Anthrazitgrau matt
gris anthracite opaque

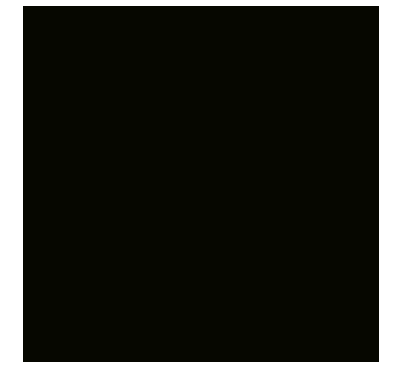

nero lucido
glossy black
Schwarz glänzend
noir brillant



rosso corallo opaco
mat coral red
Korallenrot matt
rouge corail opaque



rosso lucido
glossy red
Rot glänzend
rouge brillant



rosso opaco
mat red
Rot matt
rouge opaque



viola lucido
glossy violet
Violett glänzend
violet brillant



nero opaco
mat black
Schwarz matt
noir opaque

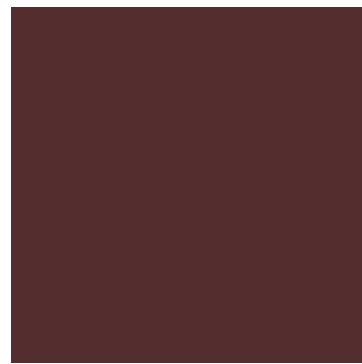

bordeaux opaco
mat bordeaux
Bordeaux matt
bordeaux opaque



amaranto opaco
mat amaranth
Amaranth matt
amarante opaque

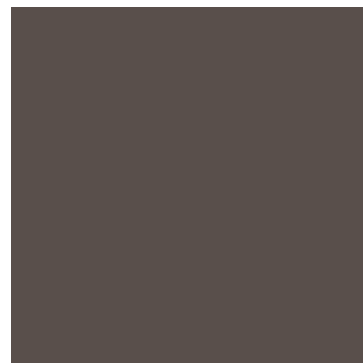

marrone opaco
mat brown
Braun matt
marron opaque

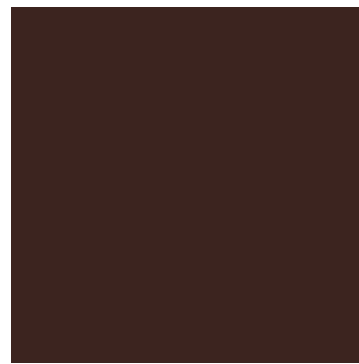

coffee brown opaco
mat coffee brown
coffee brown matt
coffee brown opaque

Metalli / Metals / Metalle / Métaux

finiture / finishes / Ausführung / finitions

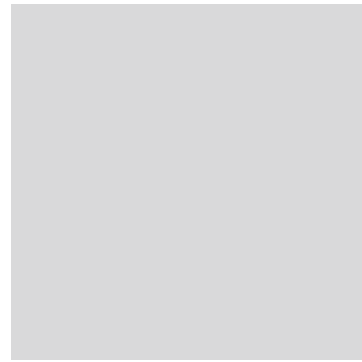

cromato
chromed
Verchromt
chromé

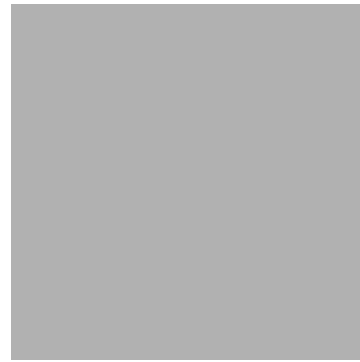

alluminio satinato
aluminium satin-finish
Aluminium satiniert
aluminium satiné



finitura brunito
burnished finish
Brüniert Ausführung
finition bruni



finitura decapato
pickled finish
Stahlgrau Ausführung
finition décapé



finitura rame
copper finish
Kupfer Ausführung
finition cuivre



finitura rame opaco
mat copper finish
Kupfer matt Ausführung
finition cuivre opaque



finitura ottone
brass finish
Messing Ausführung
finition laiton



finitura ottone opaco
mat brass finish
Messing matt Ausführung
finition laiton opaque

New Perspective Mirror - Decoro / Decor / Dekor / Structure



Comb. 1
rosso, verde, blu
red, green, blue
Rot, Grün, Blau
rouge, vert, bleu



Comb. 2
nero
black
Schwarz
noir



Comb. 3
rame
copper
Kupfer
cuivre

EOS					
	bianco white Weiss blanc				
KADOU					
	bianco white Weiss blanc	tortora dove grey Taubengrau gris tourterelle	bronzo bronze Bronze bronze	grigio antracite anthracite grey Anthrazitgrau gris anthracite	
	TREE				
		bianco white Weiss blanc	bianco lucido glossy white Weiss glänzend blanc brillant	argento lucido glossy silver Silber glänzend argent brillant	tortora dove grey Taubengrau gris tourterelle
TREE					
	oro lucido glossy gold Gold glänzend or brillant	giallo yellow Gelb jaune	arancio orange Orange orange	rosso red Rot rouge	

TREE				
	viola lucido glossy violet Violett glänzend violet brillant	blu lucido glossy blue Blau glänzend bleu brillant	verde green Grün vert	bronzo bronze Bronze bronze
TREE				
	grigio antracite anthracite grey Anthrazitgrau gris anthracite	nero lucido glossy black Schwarz glänzend noir brillant		
MUFFIN LAMP, XXLIGHT				
	bianco white Weiss blanc			
ARVO				
	bianco white Weiss blanc	tortora dove grey Taubengrau gris tourterelle	bronzo bronze Bronze bronze	grigio antracite anthracite grey Anthrazitgrau gris anthracite

Plastica / Plastic / Kunststoff / Plastique

DUFFY

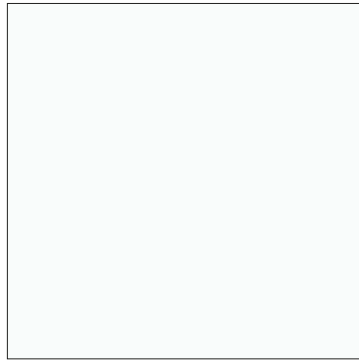

bianco
white
Weiss
blanc

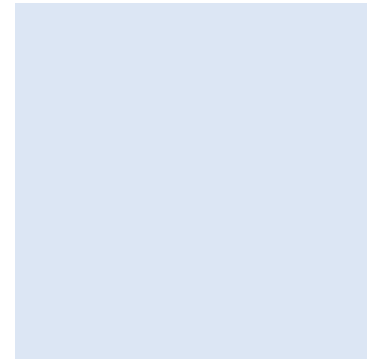

azzurro polvere
powder blue
Pulverblau
bleu poudre



grigio chiaro
light grey
Hellgrau
gris clair



grigio antracite
anthracite grey
Anthrazitgrau
gris anthracite

MUFFIN

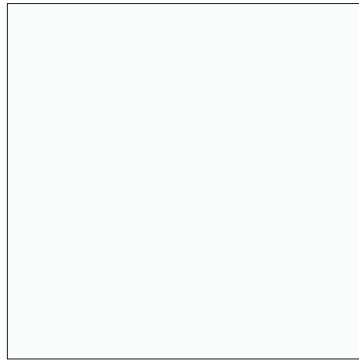

bianco
white
Weiss
blanc



tortora
dove grey
Taubengrau
gris tourterelle



rosso
red
Rot
rouge

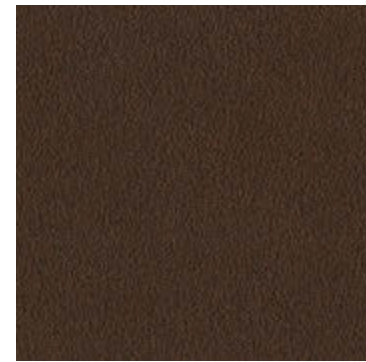

bronzo
bronze
Bronze
bronze



grigio antracite
anthracite grey
Anthrazitgrau
gris anthracite

PEBBLE

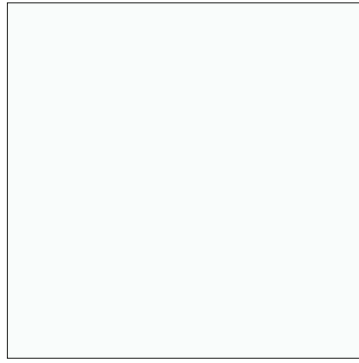

bianco
white
Weiss
blanc

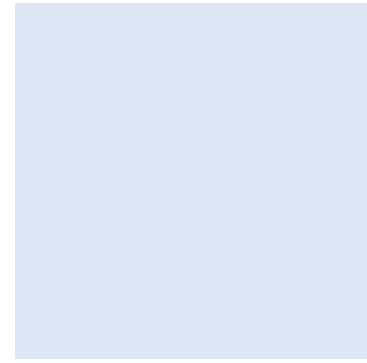

azzurro polvere
powder blue
Pulverblau
bleu poudre



rosso
red
Rot
rouge



grigio
grey
Grau
gris

PEBBLE POUF

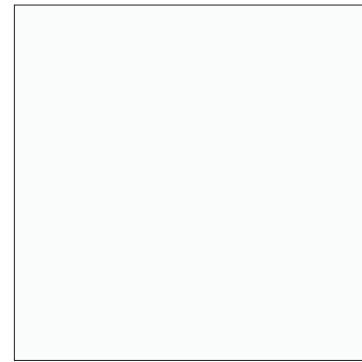

bianco
white
Weiss
blanc

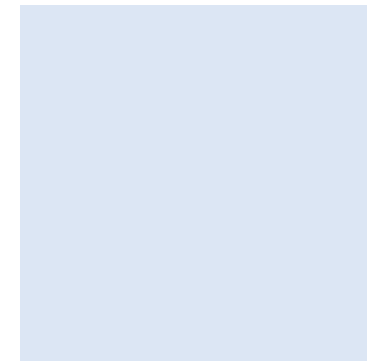

azzurro polvere
powder blue
Pulverblau
bleu poudre



rosso
red
Rot
rouge



grigio
grey
Grau
gris



LT10



LT11



LT14

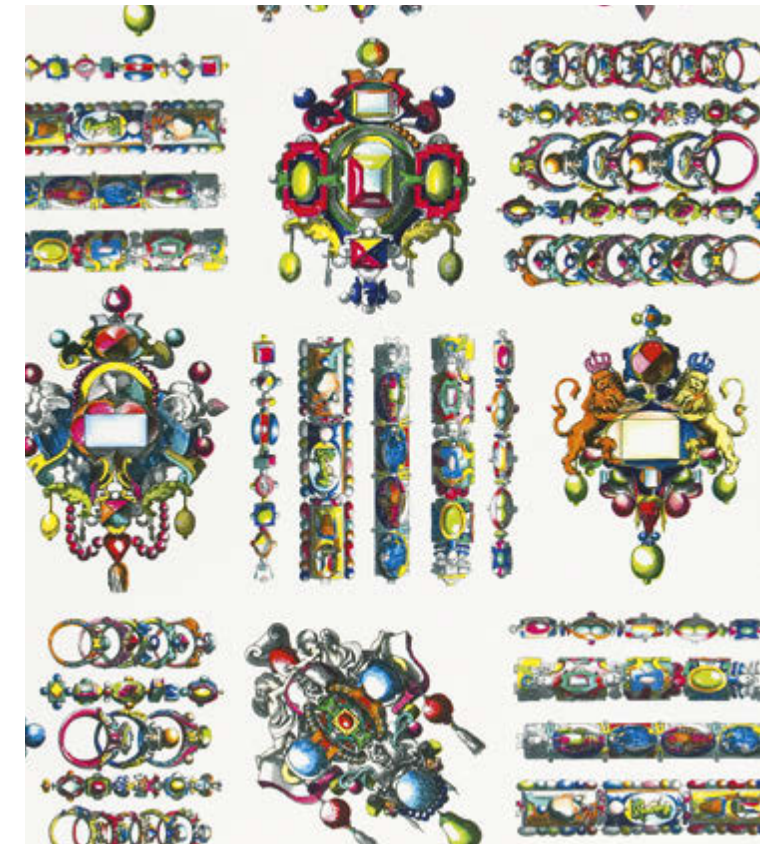

LT15



LT12



LT13



LT16

concept
romanoassociati.com

press
Grafiche Antiga

Printed in Italy
November 2016

We are social



Bonaldo SpA si riserva di modificare, senza preavviso, materiali, rivestimenti, finiture e disegni dei prodotti presentati in questo catalogo.

I colori e le finiture visualizzate sono puramente indicativi e possono differire dagli originali. Le immagini riprodotte nel presente catalogo sono di proprietà esclusiva di Bonaldo SpA.

È vietata qualunque riproduzione o utilizzo delle immagini senza preventiva autorizzazione scritta di Bonaldo SpA.

Bonaldo SpA reserves the right to change, without any notice, materials, covers, finishes and drawings of the products presented in this catalogue.

Colors and finishes shown are approximate and may differ from actual ones. All images in this catalogue are exclusive property of Bonaldo SpA.

Every reproduction or use of the images without prior written authorization from Bonaldo SpA is therefore strictly forbidden.

Bonaldo SpA behält sich das Recht vor, ohne vorherige Ankuendigung, Materialien, Ersatzbezeuge, Ausfuehrungen und Zeichnungen der in diesem Katalog vorgestellten Produkte zu aendern.

Die dargestellten Farben und Ausfuehrungen sind ungefaehre Angaben und koennen von den Originalen abweichen.

Die in diesem Katalog abgebildete Bilder sind ausschliesslich Eigentum von Bonaldo SpA.

Ohne die vorherige schriftliche Genehmigung von Bonaldo SpA ist es jede Vervielfaeltigung oder Verwendung von Bildern verboten.

Bonaldo SpA se réserve le droit de modifier, sans préavis, les matériaux, les revêtements, les finitions et les dessins des produits présentés dans ce catalogue.

Les couleurs et les finitions indiquées sont indicatives et peuvent différer des originaux. Les images reproduites dans ce catalogue sont propriété exclusive de Bonaldo SpA

Il est interdit la reproduction ou utilisation d'images sans l'autorisation écrite préalable de Bonaldo SpA.

BONALDO

Bonaldo SpA _ via Straelle, 3 35010 Villanova di Camposampiero (PD) Italy tel + 39 049.9299.011 bonaldo@bonaldo.it www.bonaldo.it